

INSTALLATION GUIDE AND OWNER'S MANUAL



Personalized Automated Control System

Table of Contents



- Important Information and System Specifications
- Introduction 2
 - Components and Accessories 4
- Installation 6
 - Plumbing Guidelines 6
 - Command Center Installation 9
 - HP (High Power) Devices 12
 - LP (Low Power) Devices 14
 - Valves 20
 - Sensors 22
 - Solar Systems 24
 - Optional Relays 26
 - Additional HP Relays 26
 - Dimmer Relay 26
 - 2-Speed Relay 28
 - Optional Eos Expansion Panel 30
 - Optional Controllers 32
 - Watermatic C2100 ORP/pH Controller 32
 - AutoClearPLUS Salt Chlorinator 32
 - Optional PLC (X-10) Devices 34
 - Optional In-House Panel (Wired Remote) 36
 - Optional Wireless Remote and Antenna 38
 - Optional Shortcut Remote 40
 - Optional RBC Hub Card 42
- Operation 44
 - Starting the Eos System 44
 - System Setup 44
 - Setup Screen 45
 - Watermatic Controller Control Screen 46
 - Salt Chlorinator Control Screen 47
 - Display Setup Screens (Command Center, In-House Panel, Wireless Remote) 47
 - Device Setup Screen 49
 - Main Screen 52
 - Device Manager 53
 - System Operation 54
 - Scenes and Shortcuts 55
 - Eos Software Applications 55
 - Service Mode 57
 - Alerts and Alarms 57
 - Safety Delays and Lockouts 58
- Warranty



Important Information

1. READ AND FOLLOW ALL INSTRUCTIONS.
2. Do not allow children to handle this product.
3. All electrical work should be performed by a licensed electrician and conform to all national, state and local codes.
4. Do not install or service this equipment if precipitation is present or imminent.
5. To avoid electrical shock, install all electrical equipment at least 5 feet (1.5 m) from inside wall of pool or spa using nonmetallic plumbing. Canadian installations must be at least three meters from the water.
6. A ground-fault circuit interrupter (GFCI) must be utilized if this device is used to control underwater light fixtures. The conductors on the load side of the GFCI should not occupy conduits, boxes or enclosures containing other conductors unless the other conductors are also protected by a GFCI. GFCI's and GFCB's should be tested daily before using the pool or spa. Refer to local codes for complete details.
7. A GROUND BAR terminal is located on the panelboard. Per NEC Article 250-122, this terminal must be connected to the ground means on the electric service or supply panel with a continuous copper (minimum 12 AWG (3.3 mm²)) insulated wire. A second wire connector should be bonded with a minimum 8 AWG (4.115 mm) copper wire to any metal ladders, water pipes, or other metal within 5 feet (1.5 m) of the pool or spa.
8. Always keep the door to the command center closed.
9. **Charge the Eos Wireless Remote battery at least 5 hours before use.**

Eos Command Center Specifications

Dimensions:	22.5" H x 17" W x 4.75" D
Input (Power Supply):	120 VAC, 50/60 Hz, 2 AMP
Output:	24 AC, 4A
High Power Relays:	4 standard (4 optional on base unit) Contact Rating (High Voltage): 25A; 3 HP at 240VAC, 1.5 HP at 120VAC
Low Power Relays:	6 standard Contact Rating (Low Voltage):10A at 120VAC
Valve Connections:	6 standard
Sensor Connections:	6 standard
Display:	Graphic, LCD, menu-driven

Introduction



Congratulations on the purchase of your new automated control system and thank you for choosing Polaris. Designed to provide easy and convenient control of most pool and spa functions, the Polaris Eos Command Center:

Controls:

- Circulation pumps
- Two-speed pumps
- Automatic pool cleaner pumps
- Water feature pumps
- Spa blowers and jet pumps
- Heat pumps
- Chillers
- Gas, propane and electric heaters
- Solar systems
- Chemical or salt chlorinators
- Electric lights
- Fiber optic lights
- Low-voltage lights



Controls valves for:

- Circulation for pool/spa combination
- Spa drain, fill and spillover
- Solar panels
- Automatic pool cleaners
- Water Features

Can control signal transmission for:

- Power Line Carrier (PLC) devices (X-10, Smarthome™, etc.)

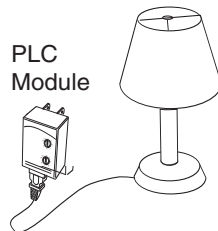

The Eos Command Center can operate alone or with any combination of the wired, In-House Panel remote, the Wireless Remote or the Shortcut remote.

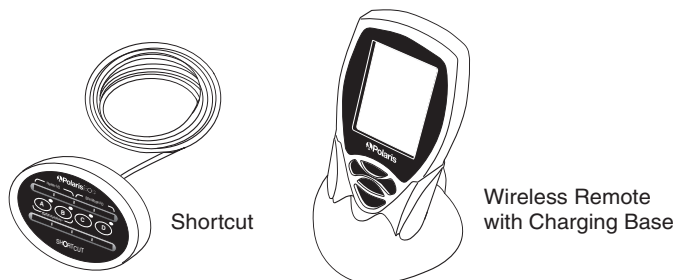

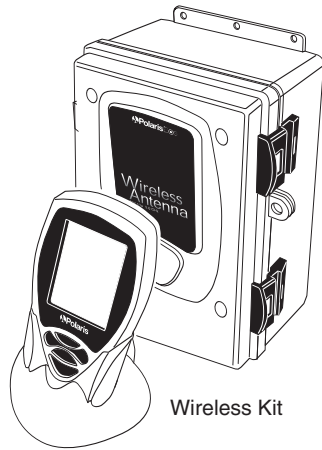

Wireless Kit

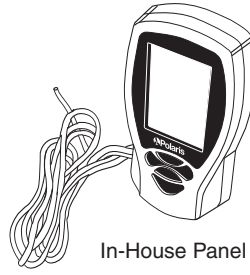

In-House Panel



Shortcut

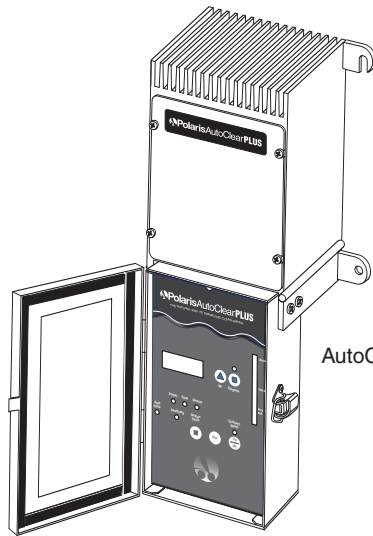

AutoClearPLUS

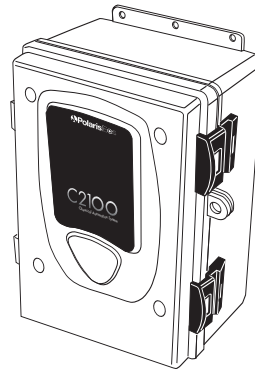

Watermatic C2100 Controller

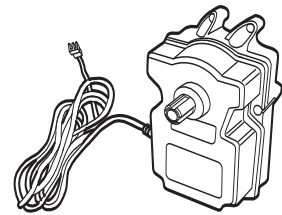

Valve Actuator

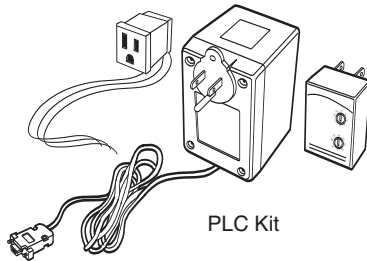

PLC Kit

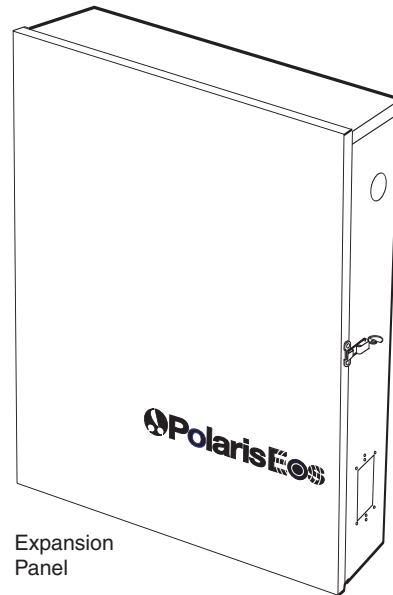

Expansion Panel



Command Center Components

- Command Center
- Mounting Brackets
- Identifier Labels for Relay Wiring
- Four High-Voltage Relays
- Temperature Sensors (2)

Accessories (Sold Separately)

- Part #E9 - Expansion Panel
- Part #S10 - Automatic Valve Actuator
- Part #S20 - Temp Sensor, 15 Ft. Cable
- Part #S22 - Solar Temp Sensor, 50 Ft. Cable
- Part #S25 - Solar Temp Sensor, 100 Ft. Cable
- Part #E71 - Pressure Sensor
- Part #S30 - High Power Relay
- Part #S50 - Surge Protection Module (Lightning Protection)
- Part #S80 - Two-Speed Pump Relay
- Part #E75 - Dimmer Relay (2000 Watt Max.)
- Part #E76 - Thermal Conductive Grease Stick
- Part #C2100 - Watermatic ORP/pH Controller
- Part #85-600 - AutoClearPLUS Salt Chlorinator
- Part #E20 - Wireless Remote Kit (Antenna, Remote and Charging Base)
- Part #E21 - In-House Panel (Wired Remote) with 125 Ft. Cable
- Part #E22 - Shortcut Remote with 125 Ft. Cable
- Part #E23 - Shortcut Remote with 250 Ft. Cable
- Part #E24 - Shortcut Remote with 500 Ft. Cable
- Part #E29 - Wireless Remote with Charging Base
- Part #E30 - Wireless Remote Only
- Part #E31 - Wireless Remote Charging Base Only
- Part #E32 - Wireless Antenna Only
- Part #E33 - Wireless Remote Battery
- Part #E34 - RBC Cable, 250 Ft.
- Part #E35 - RBC Cable, 500 Ft.
- Part #E36 - RBC Hub Card
- Part #E40 - PLC Kit (Transmitter, Outlet and E41 Dimmer Module)
- Part #E41 - PLC Dimmer Module (Lighting Only)
- Part #E42 - PLC Non-Dimmer (Lighting Only)
- Part #E43 - PLC Appliance Module
- Part #E44 - PLC Screw-In Dimmer Module (Lighting Only)
- Part #E45 - PLC Phase Coupler, 3-Wire Plug-In
- Part #E46 - PLC Phase Coupler, Hardwired

Eos Software Applications (Sold Separately)

- Part #E81 - Eos E3 Simulator (Training Software) - Free, contact Polaris
- Part #E82 - Eos PC Access Application
- Part #E83 - Eos Datalogger Application
- Part #E84 - Eos Code Download Application - Free, contact Polaris

Circuit breakers, GFCI's and three-way valves are sold separately.



Application Checklist

What will the unit control?

Equipment	Yes?	Relays Required	Valve Actuators Required
Filter Pump – 1 Speed	<input type="checkbox"/>	1	-
Filter Pump – 2 Speed	<input type="checkbox"/>	2 (1 regular, 1 2-speed)	-
Pool/Spa Combination	<input type="checkbox"/>	-	2 (1 for suction, 1 for return)
Polaris Watermatic 2100 ORP/ph Controller	<input type="checkbox"/>	0 Use CPC connection	
Salt Generator	<input type="checkbox"/>	0 Use RS-485 connector	
Cleaner Booster Pump	<input type="checkbox"/>	1	-
Pressure Side Cleaner Controlled with Automatic Valve	<input type="checkbox"/>	-	1
Spa Blower	<input type="checkbox"/>	1	-
Spa Jet Pump	<input type="checkbox"/>	1	-
Water Feature Using Separate Pump	<input type="checkbox"/>	1 Each	-
Water Feature Using Automatic Valve	<input type="checkbox"/>	-	1 Each
Pool Light	<input type="checkbox"/>	1	-
Spa Light	<input type="checkbox"/>	1	-
Dimmer	<input type="checkbox"/>	1 With Dimmer Relay	
Fiber Optic Lighting	<input type="checkbox"/>	1 For on/off control only 2 For on/off plus color wheel control	-
Heater (Gas or Propane)	<input type="checkbox"/>	0 Use heater connection	-
Heater (Electric)	<input type="checkbox"/>	0 If thermostat is low voltage 1 If thermostat is high voltage	
Solar Using Booster Pump	<input type="checkbox"/>	1	-
Solar Using Automatic Valve	<input type="checkbox"/>	-	1
High-Voltage Accessory	<input type="checkbox"/>	1 Each	-
Low-Voltage Accessory Landscape Lights, etc.	<input type="checkbox"/>	0 Use low-voltage connection	-
		__ Total (8 max.) 4 relays included	__ Total (6 max.)

If more relays or valves are needed, the Eos Expansion Panel (E9) provides 4 additional HP relays (expandable to 8), 6 LP relays and 6 valve connections.

Installation

System Plumbing Guidelines



Pool and Spa Combination

Plumb the pool system in accordance with the standard configuration of a pool and spa that share the same filter pump, filter and heater. The suction and return actuators will turn at the same time to switch between the pool, spa and spillover modes.

Position the spa at or above the level of the pool. If the spa is attached to the pool, utilize an overflow dam between the two bodies of water. If the spa is not attached, install an equalizer line that can carry full pump-flow between the spa and pool.

Plumb a check valve on the spa return line if the pool/spa combination has an elevated spa.

Plumb a 3-port valve on the suction side of the pool filter pump so the center valve port is connected to the filter pump. Connect the spa suction to one port and the pool suction to the other.

Plumb a 3-port valve on the heater output side so the center valve port is connected downstream of the heater. Connect the spa return to one port and the pool return to the other.

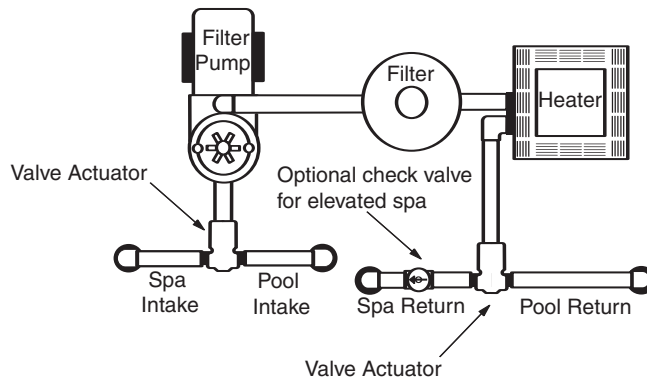



Non-Booster Pump Cleaner

Plumb a 3-port valve on the pool return line after the spa and pool return valve. Connect the pool return to one port and the cleaner dedicated line to the other port.

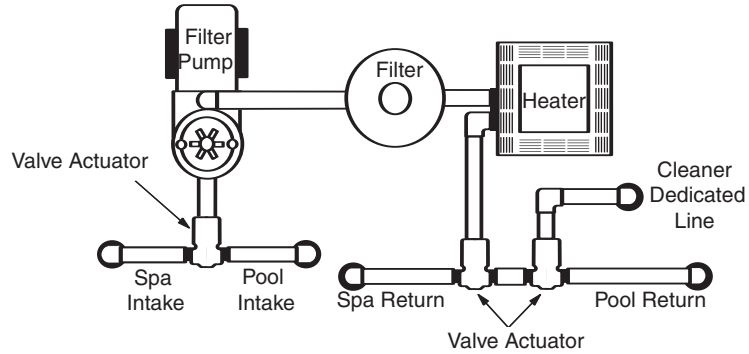

Booster Pump Cleaner

Plumb the booster pump so the suction side is connected downstream of the heater and 3-port valve on the pool return side, as near to the ground as possible.

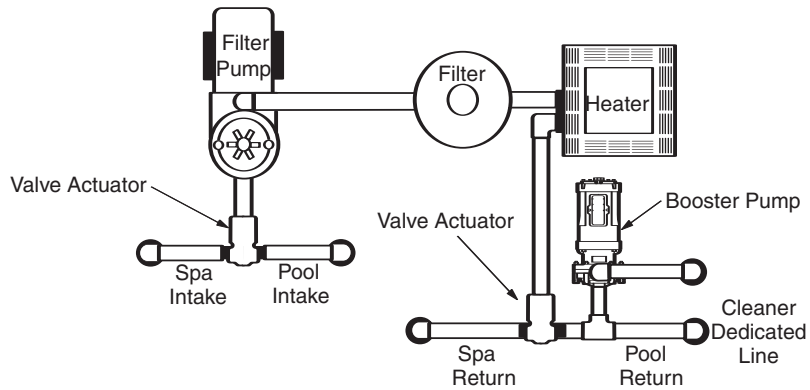

In-floor System

Plumb the valve after the heater and before the in-floor unit.

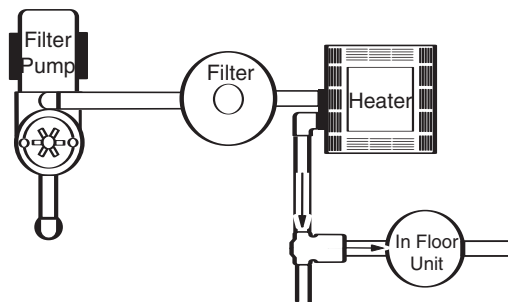

Solar System

Plumb the solar feed and return lines before the heater. Install a 3-port solar valve and actuator at the feed line.

A solar temperature sensor (50 ft or 100 ft) will be needed and should be mounted on or near the solar panels.

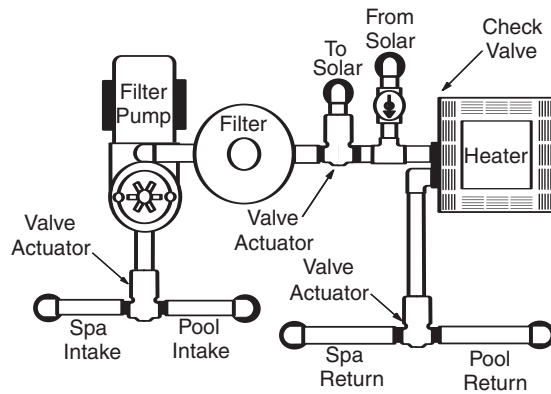

Waterfall/Water Features

Using a 3-port valve and actuator could eliminate the need for a separate pump.

If the water feature shares plumbing with other equipment and requires a booster pump, install a 3-port valve and actuator.

Use a separate pump if the water feature has its own suction supply and requires a large volume of water.

A separate booster pump can also be used to increase water flow.

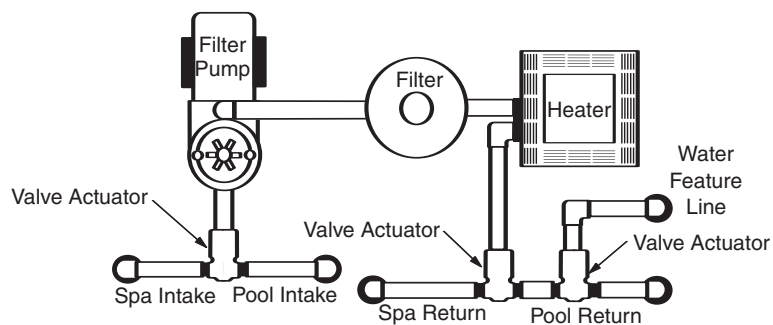



Command Center Installation

CAUTION: Verify that power is disconnected before performing any installation or modification.

1. Attach the mounting brackets (shipped inside the controller) to the command center so that the brackets extend for hanging. To facilitate function setup and adjustments, mount the command center at eye level, at least 5 ft. (1.5 m) from the pool or spa.
2. Open the command center door and remove the deadfront to gain access to the electrical components.

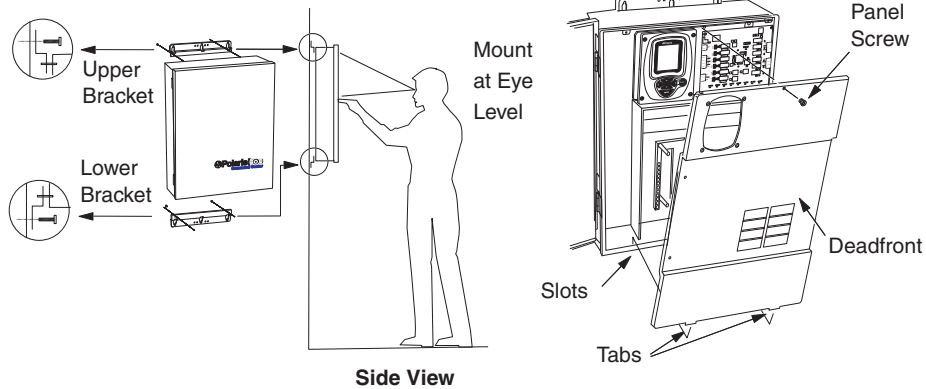

3. Run conduit from the power supply panel to the command center. The number of pieces of equipment to be controlled will dictate the size of the conduit.
4. Run wire from service panel to the Eos Command Center using minimum wire specifications listed on the wiring diagram on the command center door.
5. Pull wire, sized appropriately for each piece of equipment, from the equipment to the command center enclosure. Feeder wires should be No.14 to No. 3 AWG, copper, rated for 75° F or better.
6. Connect input to lugs on the breaker subpanel.
7. Install circuit breakers per table on wiring diagram on command center door.
8. Each piece of equipment normally requires its own high-voltage relay. If one relay is used for more than one device, verify that the total current draw (all equipment) does not exceed the current rating of the circuit.
9. Connect transformer wires to a 120V circuit breaker.
10. A GROUND BAR terminal is located on the panelboard. Per NEC Article 250-122, this terminal must be connected to the ground means on the electric supply service panel with a continuous copper (min. No. 8 AWG) bare, covered or insulated wire.

A bonding lug is provided on the exterior of the command center compartment. To reduce the risk of electric shock, connect the local common bonding grid in the area of the pool or spa to this terminal with an insulated or bare copper conductor no smaller than No. 6 AWG.

All field-installed metal components such as rails, ladders, drains, etc. located within 5 feet (1.5 m) of the pool or spa must be bonded together and to the equipment bonding lug with copper conductors no smaller than No. 8 AWG.

Before continuing:

- Ensure that all equipment motors have built-in thermal protection.
- Use the ground bar mounted in the command center for equipment grounding.
- Bond all equipment, including the command center, if necessary, to a solid ground connection.
- Install an external surge suppression device (Surge Protection Module, part #S50) in areas where lightning strikes are common.
- Use a GFCB or GFCI if direct connection of underwater lights is planned. Use the rectangular knockout on the side of the enclosure to mount an approved wiring device for this purpose. If installed outdoors, an approved rain cover must be installed over the device. Refer to NEC 680-21 (b) or CEC 687-060, 062, and 066 for further details.



HP (High Power) Devices

High power devices include pumps, lights, blowers, electric heaters and any other 120/240V device under 3HP or 1500 watts.

Four HP relays (HP1-HP4) are prewired to the Eos activator board. Four additional relays (part #S30) can be added if needed.

1. Pull equipment wiring through knockouts on the bottom of the command center box.
2. Using any HP relay, connect the device to the Eos relay panel. Use a relay identifier label to mark the connection.
3. Connect the equipment grounds.
4. When all connections are complete, assign the devices to the associated relays using Device Setup on the Setup screen. (See System Setup)

Device Setup, HP Device Options:

Combo	Pool Only	Spa Only	Separate
None	None	None	None
PS Circ Pump	Pool Circ Pump	Spa Circ Pump	Pool Circ Pump
PS Low Speed	Pool Low Speed	Spa Low Speed	Pool Low Speed
PS Heater	Pool Heater	Spa Heater	Spa Circ Pump
Pool Heater	Pool Heat Pump	Spa Heat Pump	Spa Low Speed
Spa Heater	Pool Chiller	Spa Jet Pump	Pool Heater
PS Heat Pump	Solar Pump	Blower	Spa Heater
Pool Heat Pump	Cleaner Pump	Waterfall	Pool Heat Pump
Spa Heat Pump	Waterfall	Water Feature	Spa Heat Pump
Pool Chiller	Water Feature	Spa Light	Pool Chiller
Solar Pump	Pool Light	Fiber Optic	Solar Pump
Cleaner Pump	Fiber Optic	Color Wheel	Cleaner Pump
Spa Jet Pump	Color Wheel	Lights	Spa Jet Pump
Blower	Lights	Dimmer	Blower
Waterfall	Dimmer	User Defined	Waterfall
Water Feature	User Defined		Water Feature
PS Lighting			Pool Light
Pool Light			Spa Light
Spa Light			Fiber Optic
Fiber Optic			Color Wheel
Color Wheel			Lights
Lights			Dimmer
Dimmer			User Defined
User Defined			



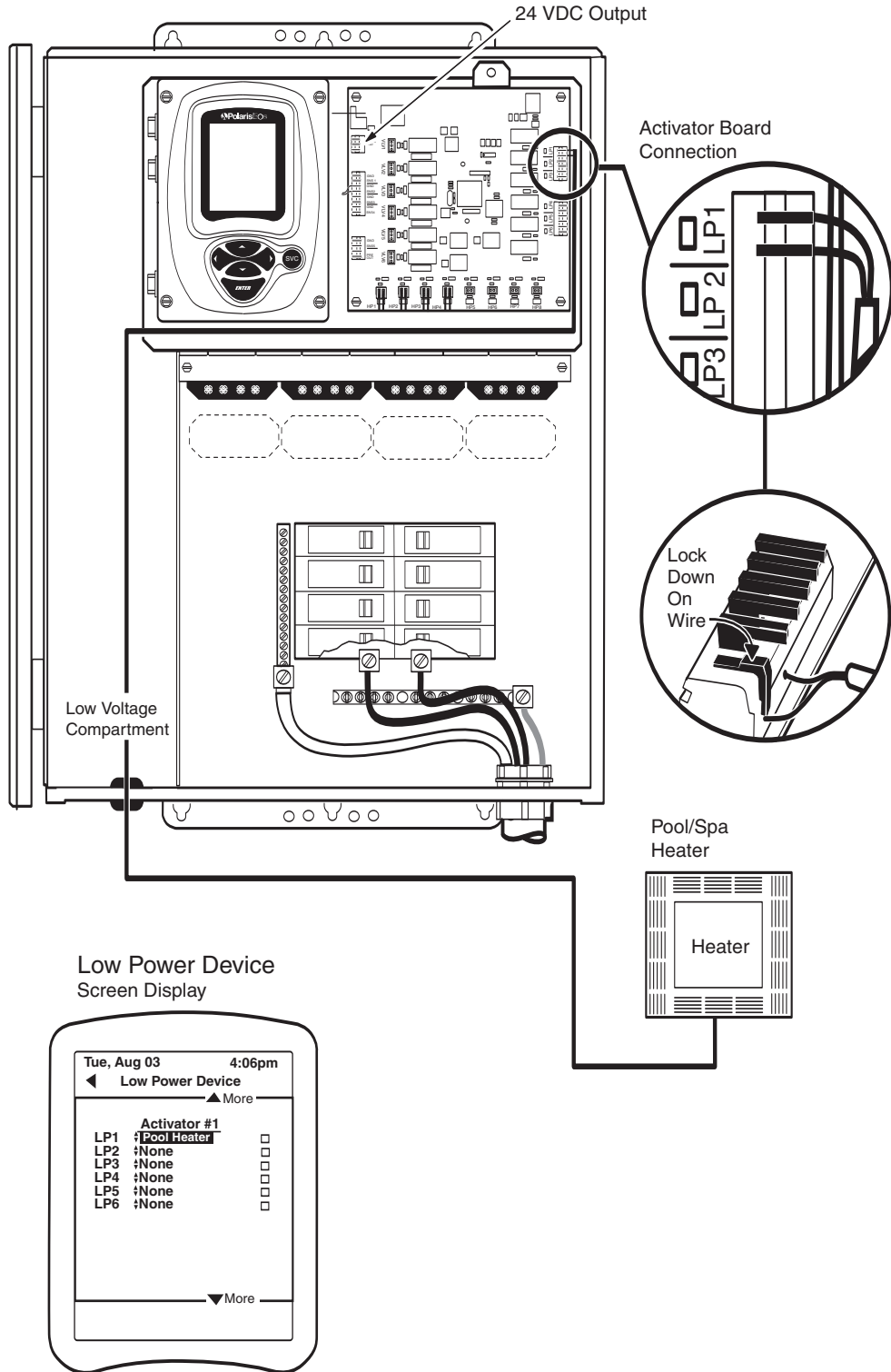



LP (Low Power) Devices

The six low power device hookups are “switch only,” with no power provided. These connections are used for heater control circuits, heat pump control circuits and self-powered landscape lighting.

1. Run equipment wires through low voltage compartment of the command center.
2. Connect the device to the LP terminal block on the Eos activator board.

A 24 VDC output (5A max.) is provided for powering low voltage triggers on equipment. This output can be run through a LP relay so it is switched manually or scheduled via the Main menu.

3. When all connections are complete, assign the devices to the associated terminals using Device Setup on the Setup screen. (See System Setup)

Device Setup, LP Device Options:

Combo	Pool Only	Spa Only	Separate
None	None	None	None
PS Heater	Pool Heater	Spa Heater	Pool Heater
Pool Heater	Pool Heat Pump	Spa Heat Pump	Spa Heater
Spa Heater	Pool Chiller	LS Lighting	Pool Heat Pump
PS Heat Pump	LS Lighting	User Defined	Spa Heat Pump
Pool Heat Pump	User Defined		Pool Chiller
Spa Heat Pump			User Defined
LS Lighting			
User Defined			



Low Voltage Heater Wiring

1. Connect two 18 AWG wires, designed for use in hot environments, to the low voltage terminal on the command center circuit board.
2. Run wiring through low voltage compartment.
3. Refer to the following heater-specific wiring instructions.

Hayward Heaters Wiring Guidelines

Models H150, H200, H250, H300, H350 and H400

1. Turn off power and remove the heater service door.
2. A terminal block for connecting remote control systems is located to the right of the electrical junction box. Attach the Eos LP wires to terminals 1 and 2. Do not remove the jumper clip on terminals 4 and 5.
3. Locate the bypass dip switch on the heater circuit board and set it to ON. The Eos now acts as the heater thermostat.
4. Turn the heater thermostat selector to the SPA position and set the heater thermostat to the maximum setting. The heater will display "bO."

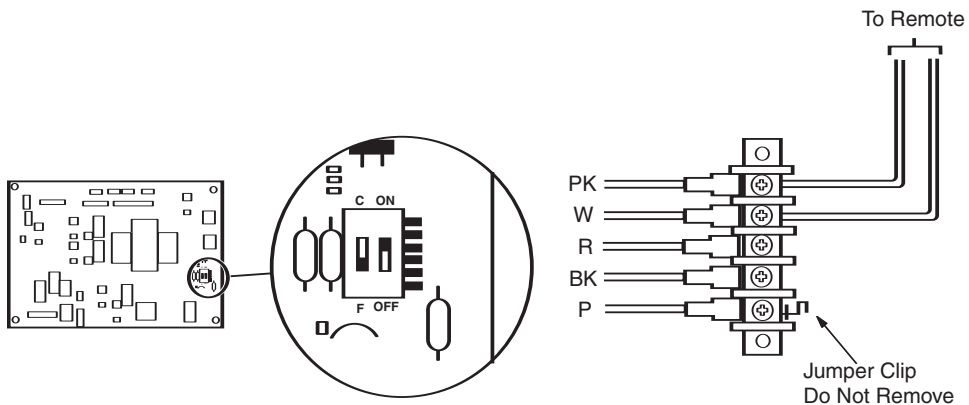



Teledyne Laars Heater Wiring Guidelines

LX and LT Series

1. Turn off power and remove the heater service door.
2. Locate the terminal strip on the left side of the raceway and remove the tagged, factory-installed jumper wire.
3. Connect Eos LP wires to the two terminals. Teledyne Laars requires the heater hookup wires to be 14-AWG copper with a temperature rating of 105° or higher.
4. Turn thermostat selector switch to either ON, HIGH or SPA and set the heater thermostat(s) to the maximum setting.

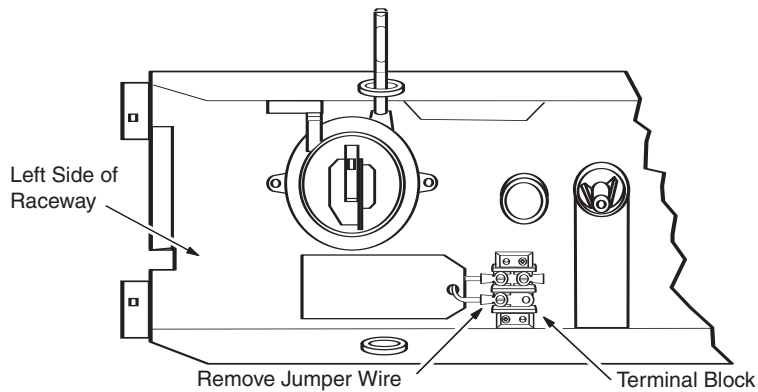

Purex Heater Wiring Guidelines

MiniMax and Tropical Isle

1. Turn off power and remove the heater service door.
2. Separate the black wires (see diagram).
3. Connect the wires from the Eos LP wires to the two black wires as shown. The violet and red wires will remain unused.
4. Turn the heater switch to the ON position and set the heater thermostat(s) to the maximum setting.
5. If connecting a Polaris Eos Wireless Remote Controller to the Purex heater, install the low voltage thermostat wires in a separate conduit from line voltage wires. Failure to separate wiring will cause the thermostat relay to react erratically.

Heater Wiring Before Modification

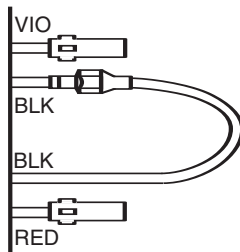

Heater Wiring After Modification

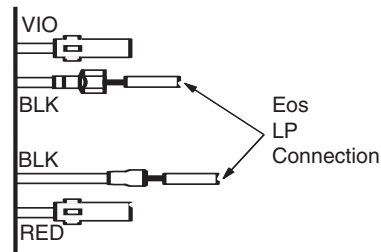



Raypak Heater Wiring Guidelines

RS2100: Models P-R185A to P-R405A and C-R185A to C-R405A

1. Turn off power. Remove screws holding the control panel and hinge panel down to expose circuit board and wire harness.
2. Locate the P7 terminal and the pigtail for external remote connection. It should be attached to the wire harness. The pigtail has a plug with three wires: one yellow/black, one orange/black, and one black/orange. If the pigtail is not present, contact Raypak at (800) 947-2975.

Plug the pigtail into the P7 terminal on the control panel circuit board.

Connect the orange/black and black/orange wires to one Eos connection wire and the yellow/black wire to the other.

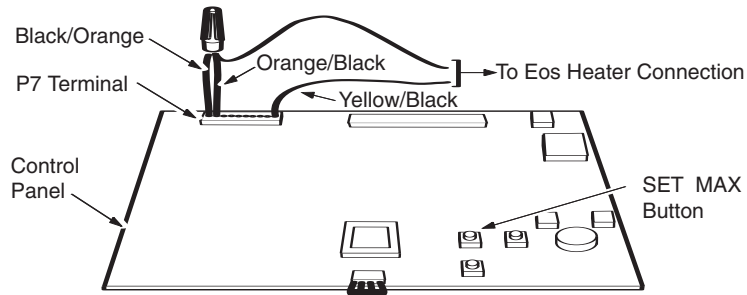

If there is no P7 terminal, connect the wires at the fireman switch location (P2 terminal, red-wire loop). Cut the loop and attach each end to one of the wires going to the Eos.

3. Hinge the control panel back into place and secure.
4. Use the touch pad on the heaters control panel to set it to OFF mode. This allows thermostat control by the Eos. The heater LCD will alternately flash "REM" and the water temperature.

If following the Raypak installation manual, use the "Two-Wire Remote System" instructions.

Raypak recommendations:

For runs of under 30 feet, remote wiring should have stranded conductors with a minimum of 22 AWG, 600V, cable twisting 1.5 to 2.5 and jacketed.

For runs over 30 feet, the conductors should be a minimum of 20 AWG, 600V, and cable twisting 1.5 to 2.5, shielded and jacketed.

Maximum cable length of 200 feet.

AquaCal AquaTherm Heat Pump Connections

AT400-D, AT600-D, AT800-D Digital "Black Cabinet" series

1. Turn off power, remove the access panel and locate the circuit board.
2. Remove metal jumper from terminals marked "Jandy/Compool".
3. Attach Eos LP wires to these terminals.

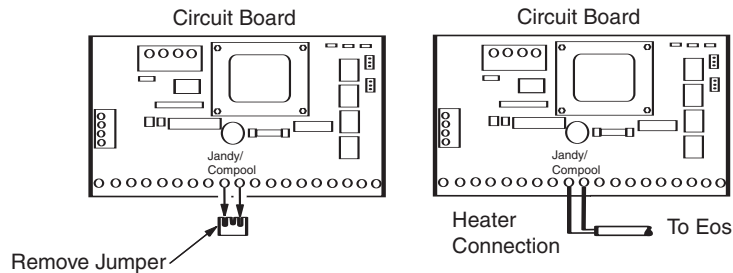

Sta-Rite Heater Wiring Guidelines

SR200NA/LP, SR333NA/LP, SR400NA/LP

Do not follow the Sta-Rite directions for Jandy remote connections. The Eos must be wired into the "Fireman Switch" terminal block.

1. Turn off power and remove jacket halves of the heater. Remove control panel assembly dome.
2. Open the control box cover and remove the factory-installed jumper between the "Fireman Switch" terminals.

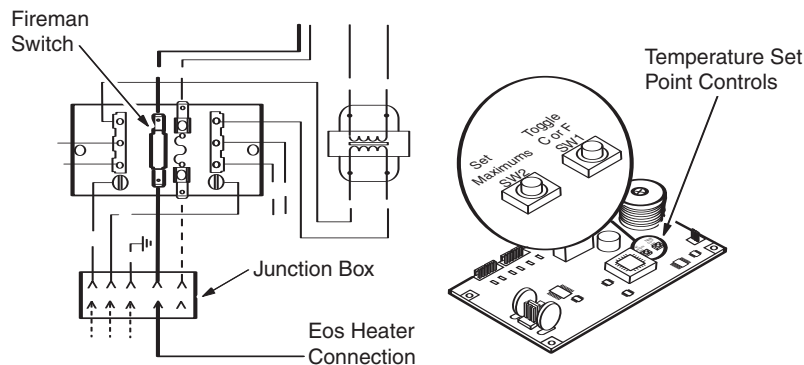

3. Connect the LP wires to these terminals, routing the wires through the knockout on the bottom of the heater control box.
4. Use a 90 degree conduit fitting on the control box and run conduit out through the cutout on the heater, next to the junction box.
5. Turn power on to the heater. Push the "Set Maximums" button on the back of the circuit board. The "POOL ON" light should come on. Press the up temp button until the maximum temperature is reached.
6. Wait 5 seconds and the "SPA ON" light will come on. Press the Up Temp button on the front panel display until the maximum temperature is reached.
7. After 5 seconds, the "SPA ON" light will go off and the unit will shut down.
8. Reassemble the heaters dome and jacket halves.

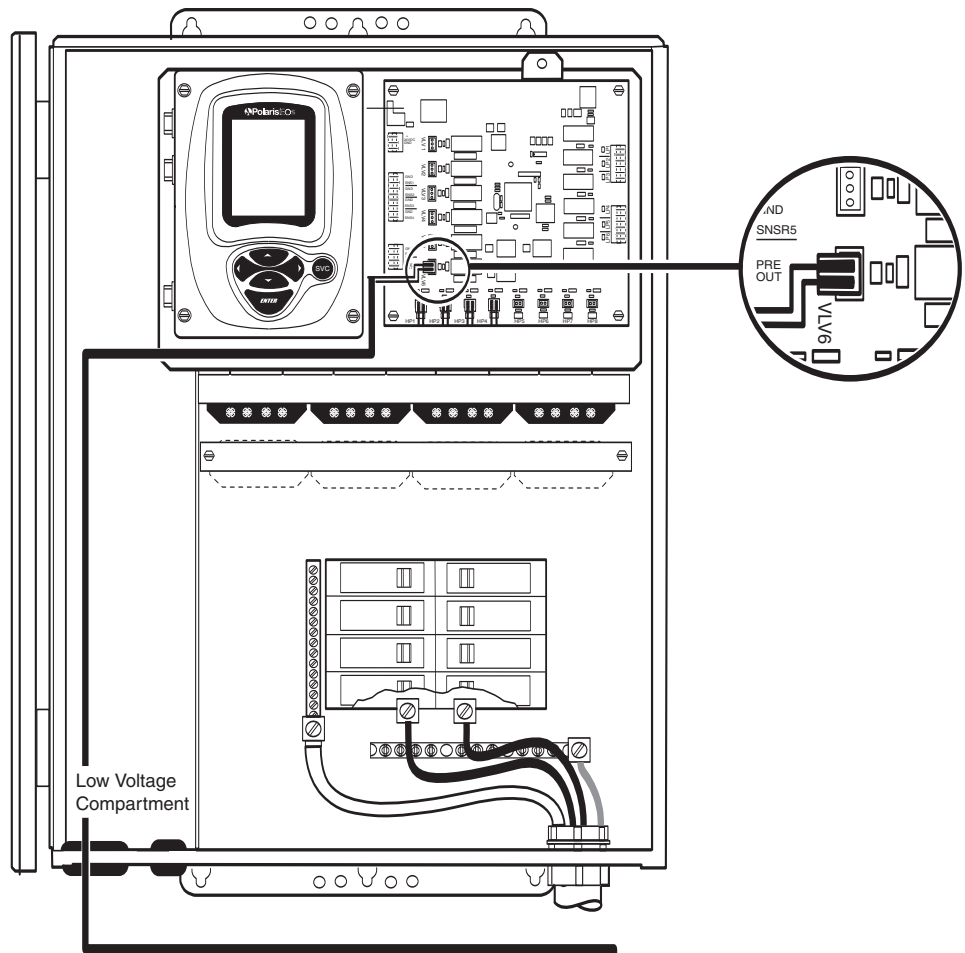

Valve
Screen Display

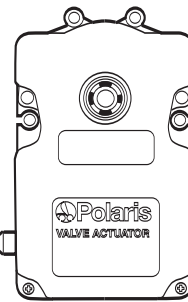
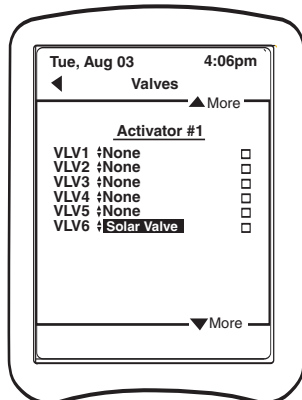

Valve Actuator

Valves

The Eos can control up to six valve actuators.



Applications

Pool/Spa Combinations - One valve actuator for suction and one for return.

Waterfall/Feature Valve and Cleaner Valve- Plumb valve after filter and heater.

In-floor System Valve - Plumb valve after the heater and before the in-floor system equipment.

Spa Dependent Valve - Used to apply a specific valve action during Spa mode. When selected, Spa Dep Valve allows the user to specify an on or off position for a particular valve. When Spa mode is active, the valve will turn to the chosen position.

Wiring

1. Run valve actuator wires through low voltage compartment of the command center. Do not coil valve actuator cable inside the command center.
2. Connect valve wires to the VLV terminal block on the Eos activator board.
3. When all connections are complete, assign the valves to the associated terminals using Device Setup on the Setup screen. (See System Setup)

Device Setup, Valve Options:

Combo	Pool Only	Spa Only	Separate
None	None	None	None
Solar Valve	Solar Valve	Backwash Supply	Solar Valve
Cleaner Valve	Cleaner Valve	Backwash Supply	Cleaner Valve
Suction Valve	Backwash Supply	Feature Valve	Backwash Supply
Return Valve	Backwash Drain	Waterfall Valve	Backwash Drain
Spa Dep Valve	Feature Valve	User Defined	Feature Valve
Backwash Supply	Waterfall Valve		Waterfall Valve
Backwash Drain	Infloor Valve		Infloor Valve
Feature Valve	User Defined		User Defined
Waterfall Valve			
Infloor Valve			
User Defined			

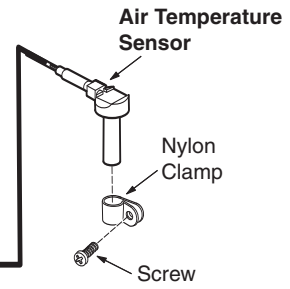
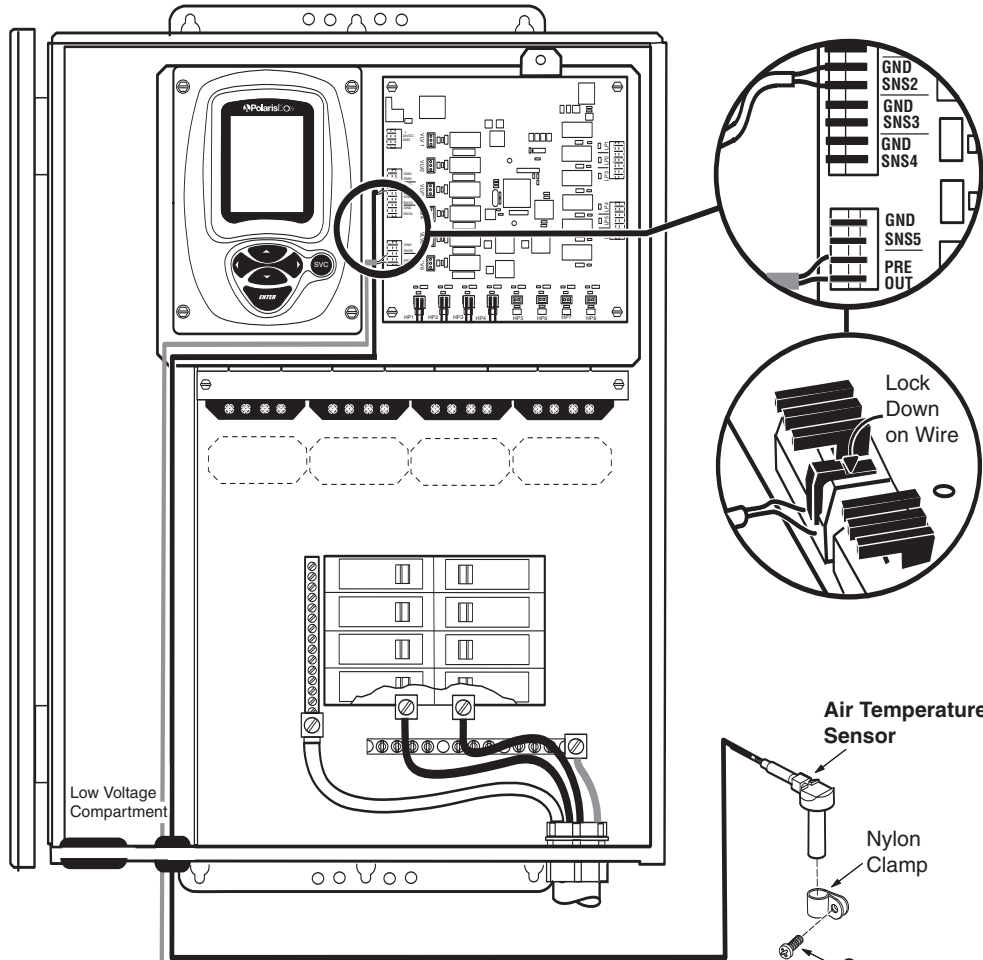

Sensor
Screen Display

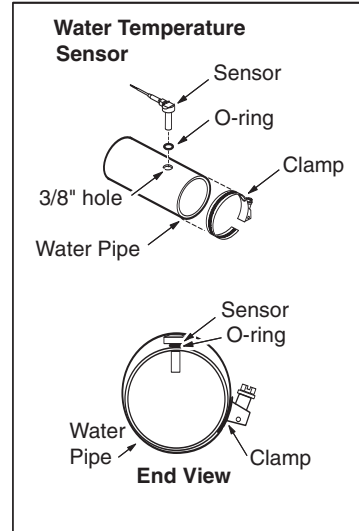
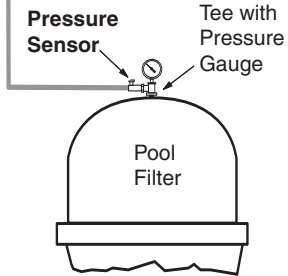
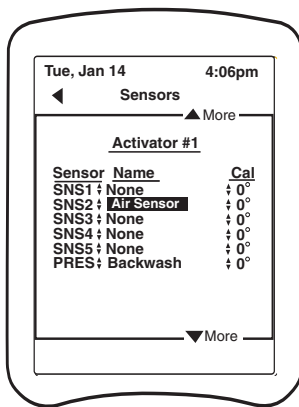

Sensors



Two standard sensors are included with the Eos system, one water and one air temperature sensor. There are four additional terminal positions available, three for optional temperature sensors and one for an optional filter pressure sensor.

Installation

Water Temperature Sensor - Drill a 3/8" hole in the pipe between the filter pump and the filter. Insert the sensor using the clamp provided to hold it in place. Verify that the o-ring is securely placed around the sensor to ensure a watertight seal.

Freeze/Ambient Air Temperature Sensor - Install the sensor outside of the command center in an area where it will be subjected to shaded air temperature, but not to direct sunlight.

Filter Pressure Sensor - Install on the filter at the pressure gauge, either using the gauge connection or using a tee.

Wiring

1. Run equipment wires through low voltage compartment of the command center.
2. Connect the temperature sensors to any position (SNS1- SNS5) on the removable terminal block on the Eos activator board. Connect the pressure sensor to the PRE OUT terminal position.
3. Connect the equipment grounds.
4. When all connections are complete, assign the sensors to the associated terminals using Device Setup on the Setup screen. (See System Setup)

Device Setup, Sensor Options:

Combo	Pool Only	Spa Only	Separate
None	None	None	None
Air Sensor	Air Sensor	Air Sensor	Air Sensor
PS Sensor	Pool Sensor	Spa Sensor	Pool Sensor
Pool Sensor	Solar Sensor	Solar Sensor	Spa Sensor
Spa Sensor	User Defined	User Defined	Solar Sensor
Solar Sensor			User Defined
User Defined			

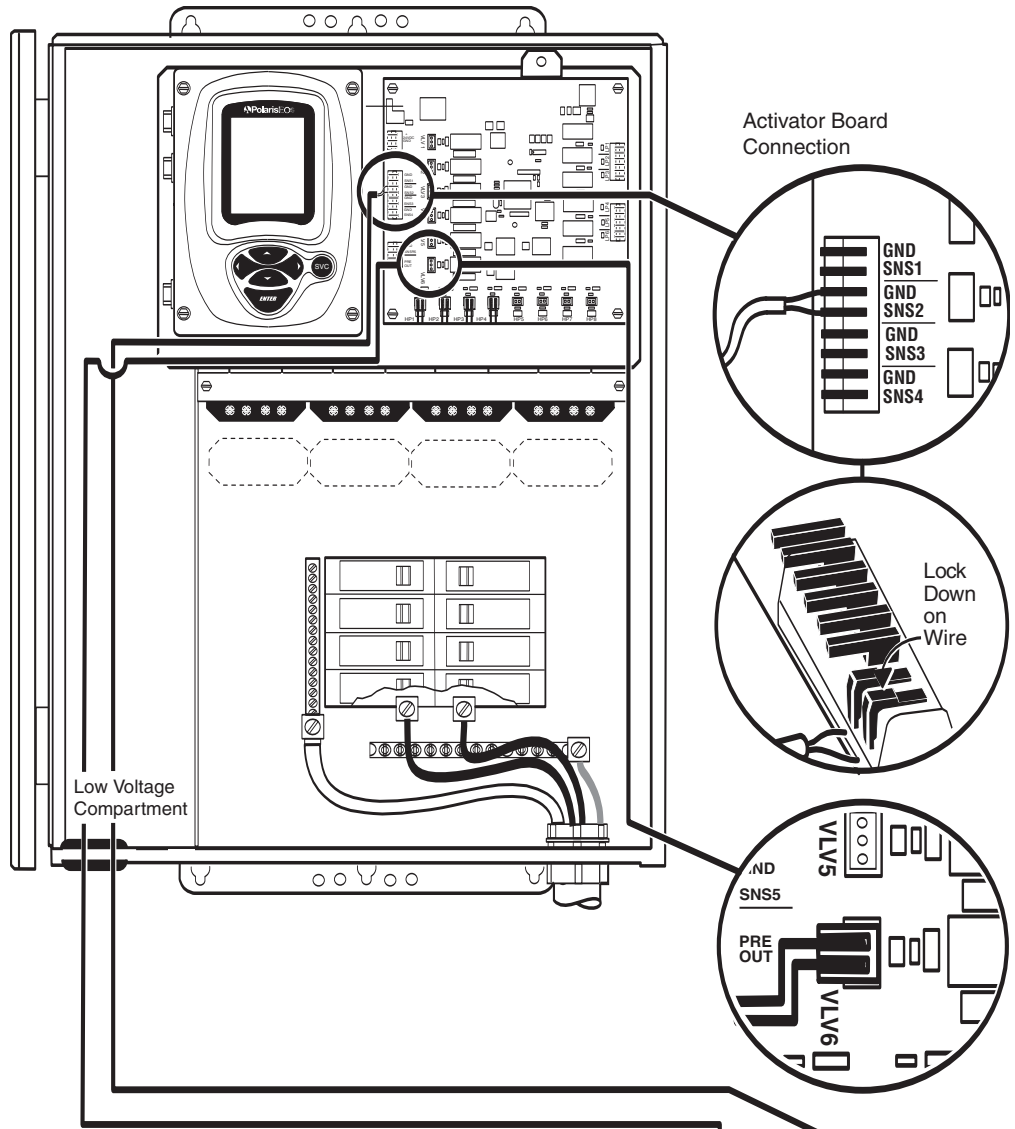

Solar Temperature Sensor

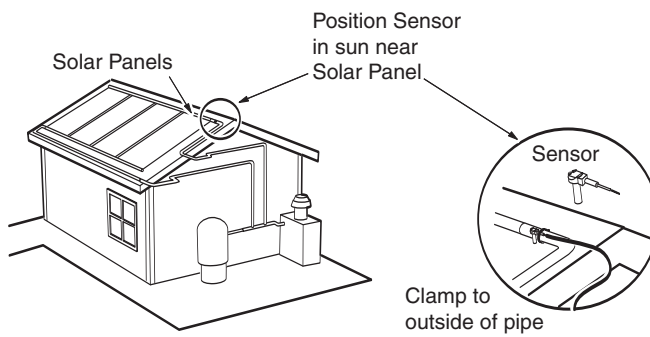

Sensor

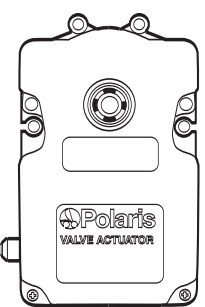

Valve Actuator

Solar Heating Systems

If the application includes a solar system, a separate solar temperature sensor must be installed. Position the solar sensor adjacent to the solar panels.

The solar heating feature will operate only if the sensor reads at least 4 degrees warmer than the pool water. Solar heating cannot be scheduled.

Plumb the solar heating valve before the heater.

Wiring

1. Run the valve actuator and sensor wires through the low voltage compartment of the command center.
2. Connect the sensor to the SNS terminal block and the valve to the VLV terminal block on the Eos activator board.
3. If there is a booster pump on the solar system, connect the pump to any available HP relay.
4. When all connections are complete, assign the sensor, solar heater and pump, if one is installed, to the associated relays using Device Setup on the Setup screen. (See System Setup)



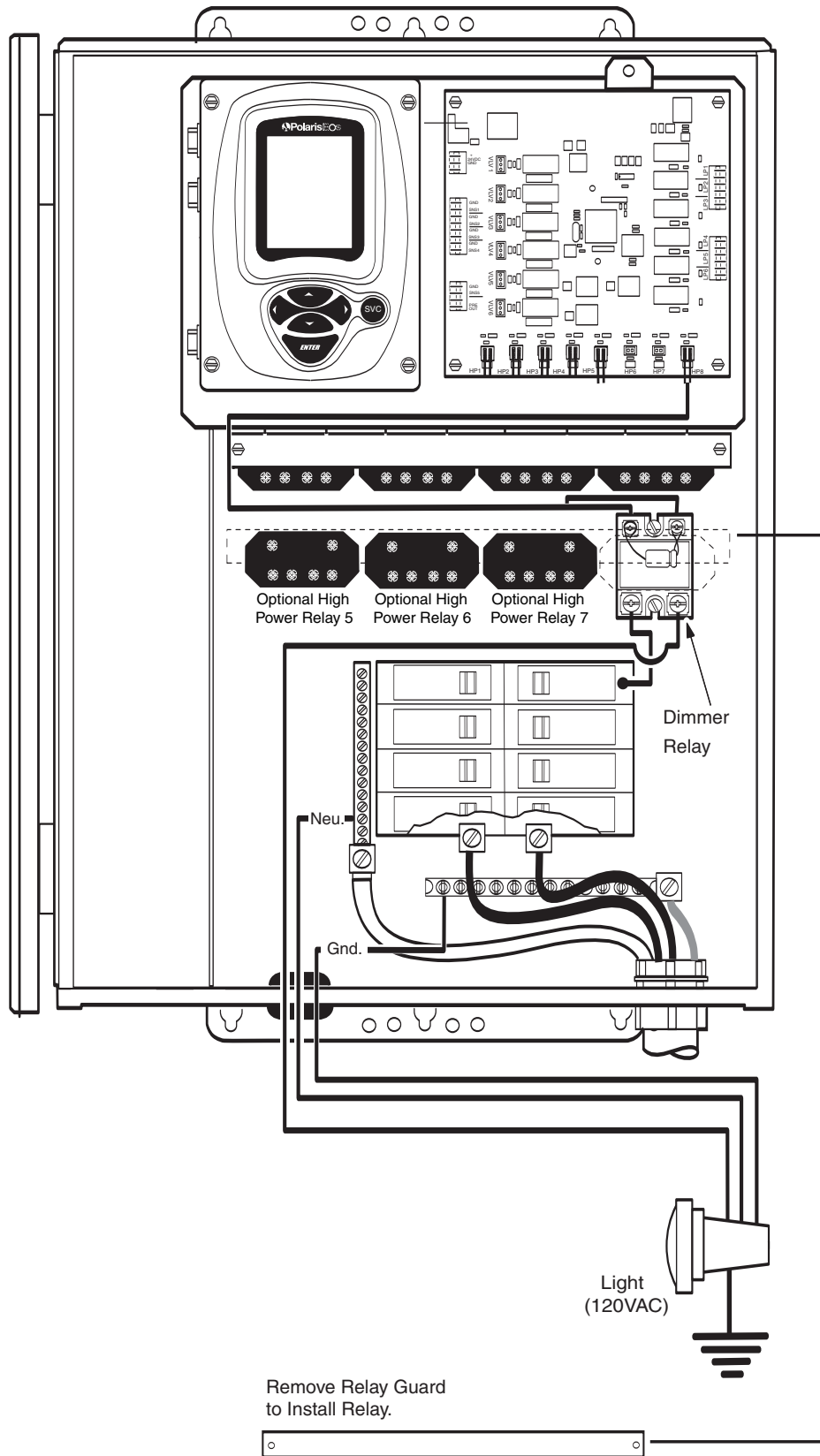



Optional Relays

Additional HP Relays

Additional high power relays (part # S30) can be added to the Eos Command Center relay panel. Connect the relays to any of the open positions on the lower portion of the panel.

Connect the relay wires to any open relay driver (HP5-8) on the command center activator board.

Label the relay connections with the wire identifier labels provided.

Dimmer Relay

Mount the dimmer relay (part #E75) to the HP7 or HP8 relay position on the lower portion of the command center relay panel. Use thermal conductive compound or a pad behind the relay. Mount the unit vertically using the predrilled holes.

Connect the relay wires to any open HP relay position on the command center activator board. Use a relay label to mark the connection.

When the connection is complete, assign the dimmer to the associated terminal using Device Setup (HP) on the Setup screen. (See System Setup)

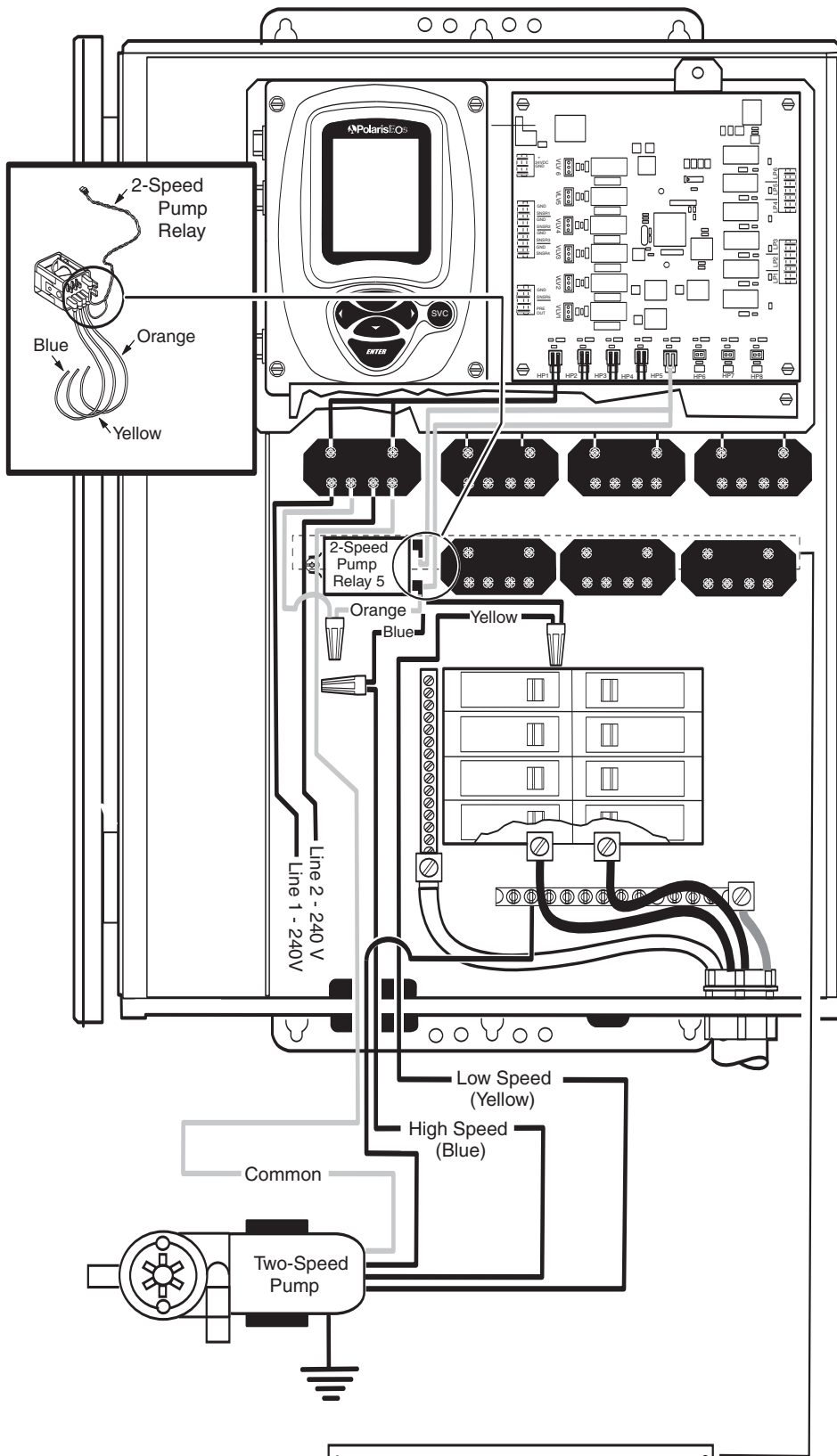

Remove Relay Guard To Install
Dimmer Relay



2-Speed Pump Relay

Mount the 2-speed pump relay (part # S80) in any open high power relay position on the lower portion of the command center relay panel.

Connect the relay wires to any open relay driver on the command center activator board. Use a relay label to mark the connection.

Connect the motor and 2-speed relay load and line wires:

- Low speed wire to Yellow wire
- High speed wire to Blue wire
- Common wire to one Load side of the filter pump relay
- Orange wire to other Load side of the filter pump relay

When the connection is complete, assign the standard relay for high speed and the 2-speed relay for low speed to the associated terminal using Device Setup (HP) on the Setup screen. (See System Setup)

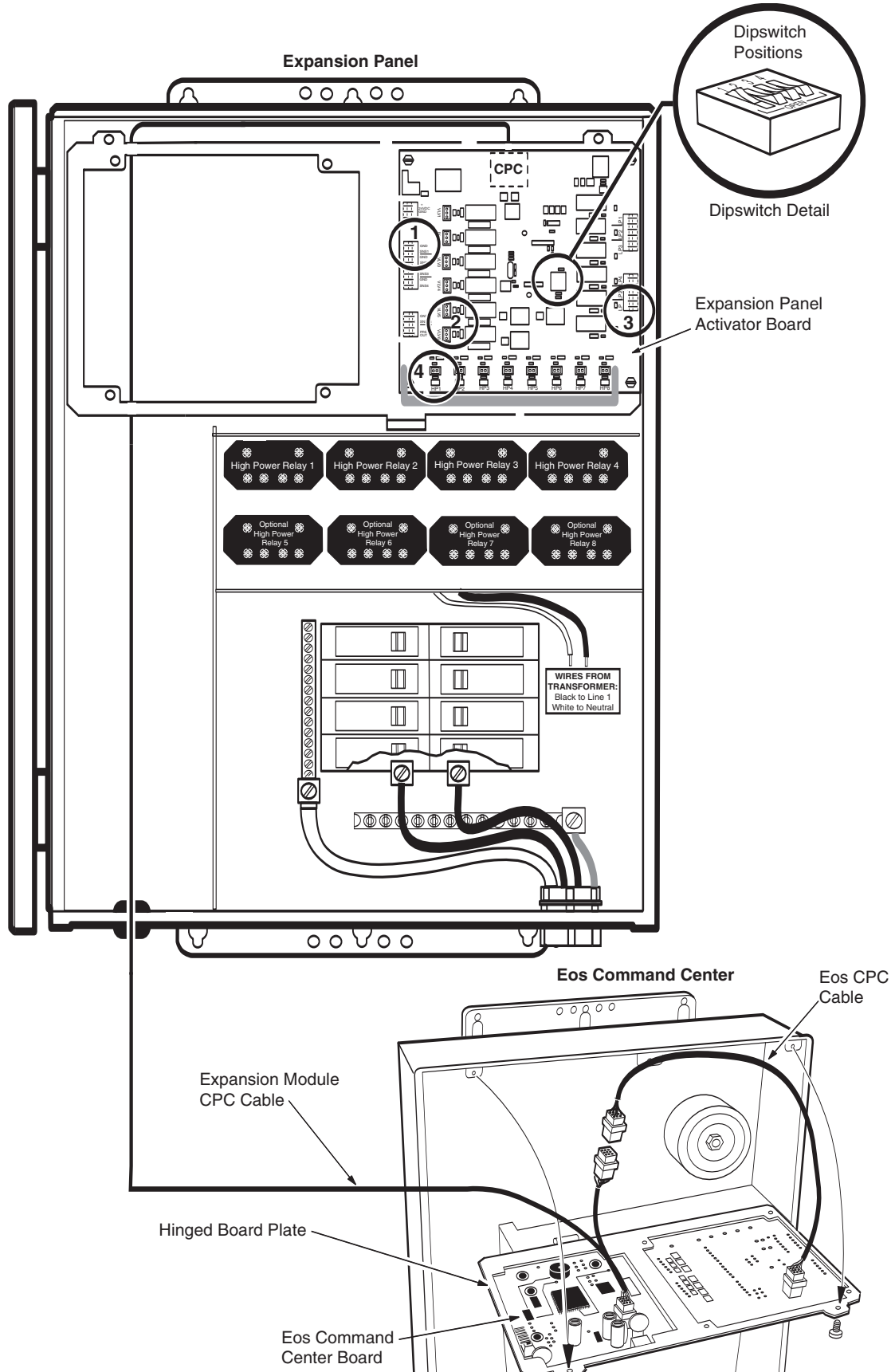

Optional Eos Expansion Panel



If additional relays and valves are needed, connect the Eos Expansion Panel to provide 8 additional high power connections, 6 low power connections, 6 valve connections and 6 sensor (5 temperature and one pressure) connections. The Eos system can accommodate up to three expansion units to provide up to 32 device connections.

1. Open expansion unit door and remove deadfront to access electrical panel.
2. Run appropriately sized conduit and wire from the main power supply to the expansion box.
3. Connect input to lugs on the breaker subpanel and install circuit breakers.
4. Connect transformer wires to a 120V circuit breaker.
5. Connect ground means on the electric supply service panel to the GROUND BAR terminal located on the expansion panelboard using continuous copper (minimum No. 8 AWG) bare, covered or insulated wire.

Use insulated or bare copper conductor, no smaller than No. 6 AWG, to connect the local common bonding grid in the area of the pool or spa to the bonding lug located on the exterior of the expansion box.

6. Locate the dip switches on the expansion panel activator board and verify that they are set appropriately. The panel is shipped as Activator #2, so subsequent panels will need to be adjusted.

Unit	Board	Dip Switch Settings
Command Center	Activator #1	All dip switches open
First Expansion Panel	Activator #2	Close position #1
Second Expansion Panel	Activator #3	Close position #2
Third Expansion Panel	Activator #4	Close position #1 and #2

7. At the Eos command center, remove deadfront then unscrew and swing down the hinged board plate to access the command center circuit boards.
8. Unplug the Eos CPC cable from the command center board. Plug one end of the Expansion Panel CPC cable into the command center board and the other end into the Eos CPC cable connected to the Eos activator board.

If a Watermatic C2100 is installed, daisy chain the command center connection to accommodate both units.

If multiple expansion panels are being utilized, daisy chain the command center connection to accommodate the units.

9. Pull wire, sized appropriately for each piece of equipment, to the expansion unit. Follow the instructions specified in this manual for each type of connection, 1. - Sensors, 2. - Valves, 3. - LP Devices and 4. - HP Devices.
10. When all connections are complete, use the command center or remote keypad to assign each piece of equipment to the associated terminals using Device Setup on the Setup screen. (See System Setup)



ORP/pH Controller

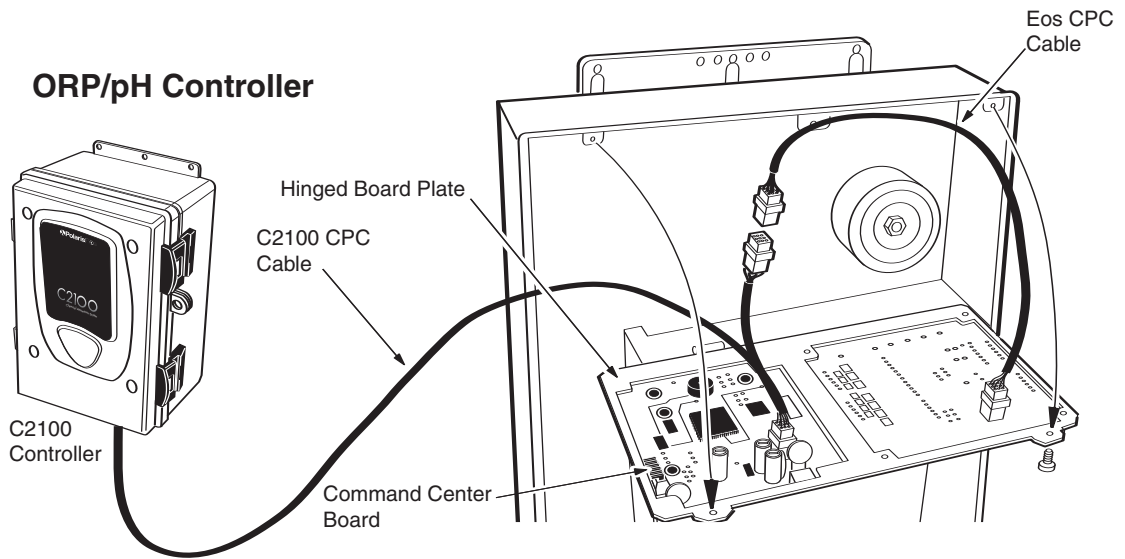

Salt Chlorinator

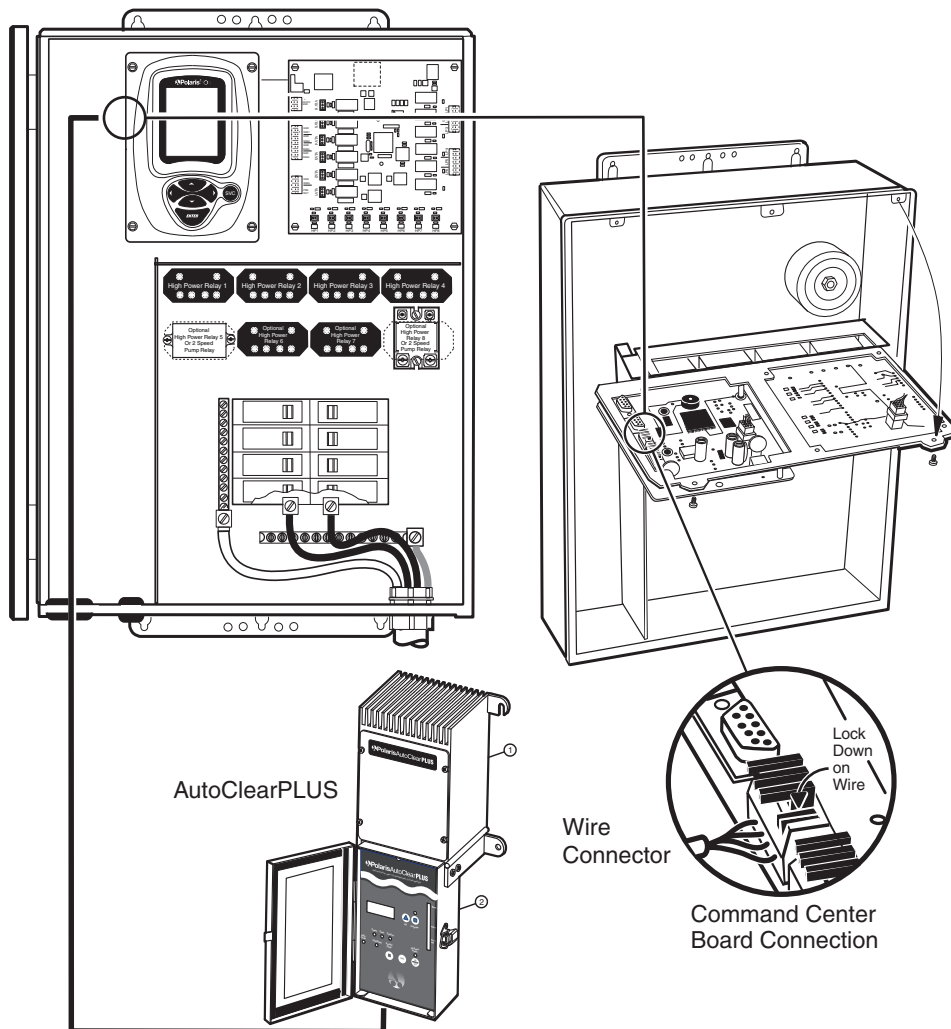

Optional Controllers



Polaris Watermatic C2100 ORP/pH Controller

ORP and pH level monitoring and control are available with the Eos when the Polaris Watermatic C2100 controller is installed on the system.

Refer to the controller owner's manual for site selection and installation instructions.

1. At the Eos command center, unscrew and swing down the hinged board plate to access the command center circuit boards.
2. Route the Watermatic CPC cable through the low voltage compartment.
3. Unplug the Eos CPC cable from the command center board. Plug one end of the C2100 CPC cable into the command center board and the other end into the CPC cable connected to the Eos activator board.

Salt Chlorinators

Clean, environmentally friendly chlorination is available with a Polaris AutoClearPLUS salt chlorination system. The Eos is also compatible with some competitor's models such as the Goldline AquaRite.

Refer to the chlorinator owner's manual for site selection and installation instructions.

1. At the Eos command center, unscrew and swing down the hinged board plate to access the command center circuit boards.
2. Route the chlorinator cable through the low voltage compartment. Attach the chlorinator wires to the 4-pin removable connector on the command center board using the following pin/wire color sequence (AutoClearPLUS and AquaRite).

Pin #	Wire Color
1 (Signal +)	Black
2 (Signal -)	White/Yellow
3 (Ground)	Green
4 (Power)	Red

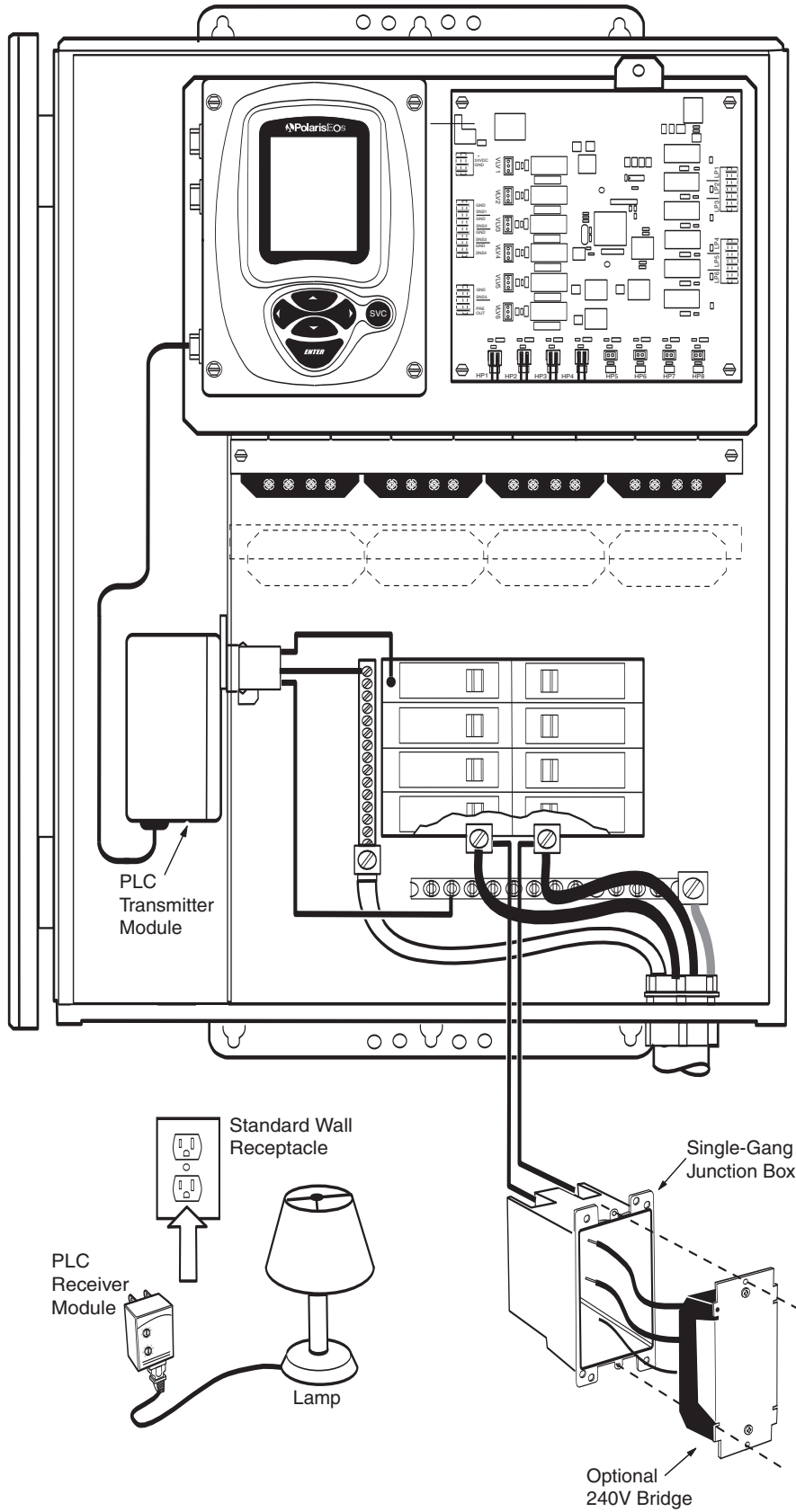



Optional PLC (X-10) Devices

The Power Line Carrier (PLC) kit provides a convenient, alternative method for controlling high power devices such as lights. Devices plug into a small PLC receiver that plugs into a regular wall outlet inside the house. The receiver communicates with a transmitter module connected to the Eos Command Center. Once set up, the device can be toggled on or off as if it were wired directly to the Eos controller.

Installation and Wiring

1. Snap U-ground plug through cutout on wall of low voltage compartment. Plug should face circuit breakers and ground terminal.
2. Attach neutral and ground wires to respective terminals.
3. Attach line wire to circuit breaker.
4. Plug PLC transmitter into U-ground plug.
5. Attach PLC cable to the command center board.
6. Set the house code (A-P) and device code (1-16) on the PLC receiver. A separate receiver is needed for each device.
7. Plug the PLC receiver into any wall plug and the device into the receiver.
8. When all connections are complete, name and assign house and device codes for each PLC device using Device Setup on the Setup screen. (See System Setup)

Up to 256 devices can be added to the system, including dimmers for lights. When house circuits are not linked to the Eos via the circuit breaker box, it may be necessary to add a bridge or phase coupler (part #E46) at the breaker box or directly onto the command center breaker subpanel.

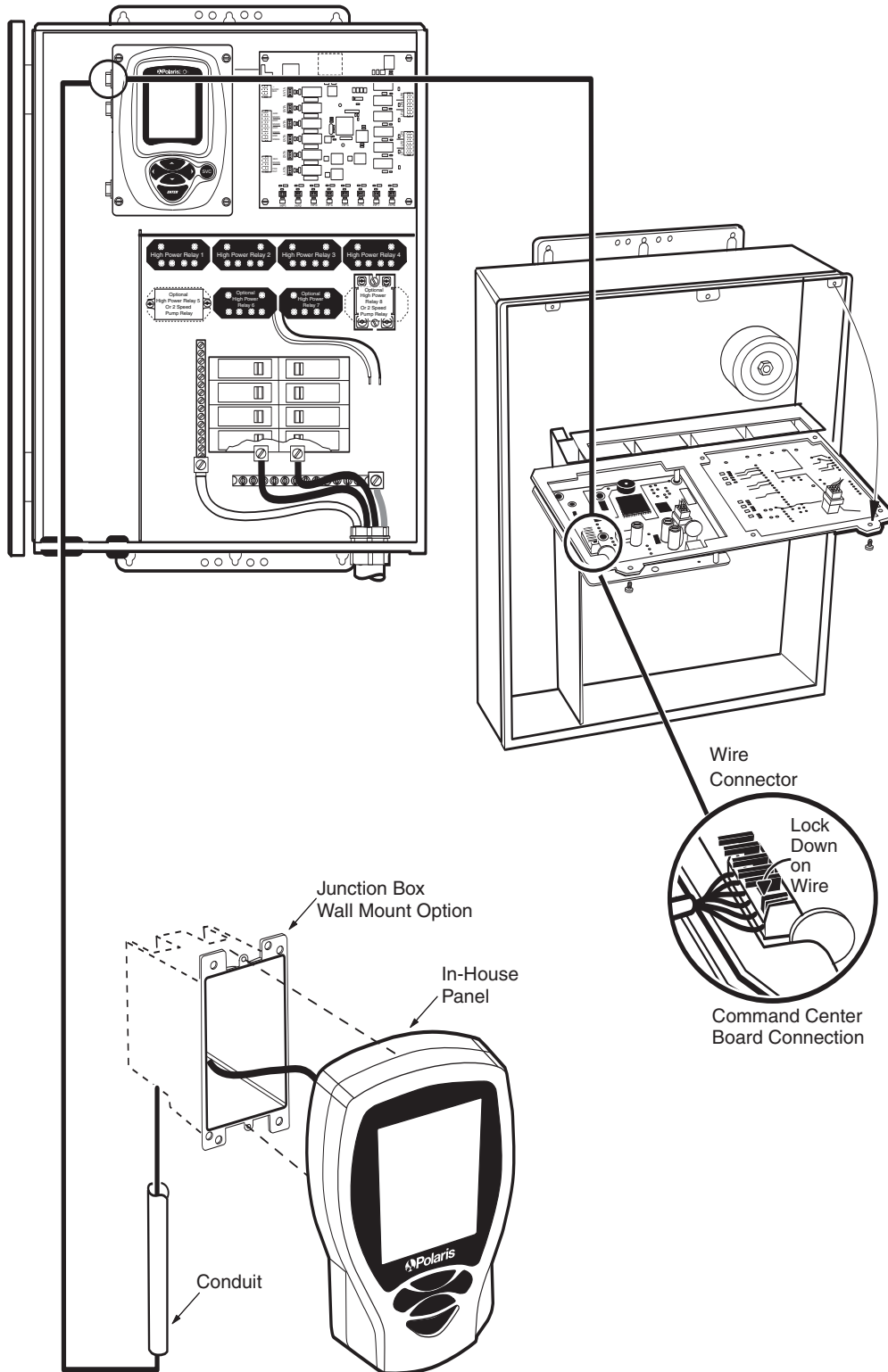

In-House Panel

Optional In-House Panel (Wired Remote)



Position the wired remote away from prolonged direct sunlight.

1. Pull the 8-wire cable through the wall and connect to the header on the back of the wired remote using the following pin/wire color sequence.

Pin #	Wire Color
1	Green
2	Yellow
3	Orange
4	Red
5	Blue + Brown
6	Black + Purple

2. **If using a junction box**, screw the screws included into the holes of the junction box. Slide wired remote onto screws.

If using a wall mount, use a level and template to measure, then drill two pilot holes into the wall. Install anchors and screws, then slide wired remote onto screws.

3. At the Eos Command Center, unscrew and swing down the hinged board plate to access the command center circuit boards.
4. Route the remote cable through the low voltage compartment. Connect the remote wires to the removable terminal block on the command center circuit board using the same pin/wire sequence set.

To connect multiple remotes, install a RBC Hub Card (part #E36).

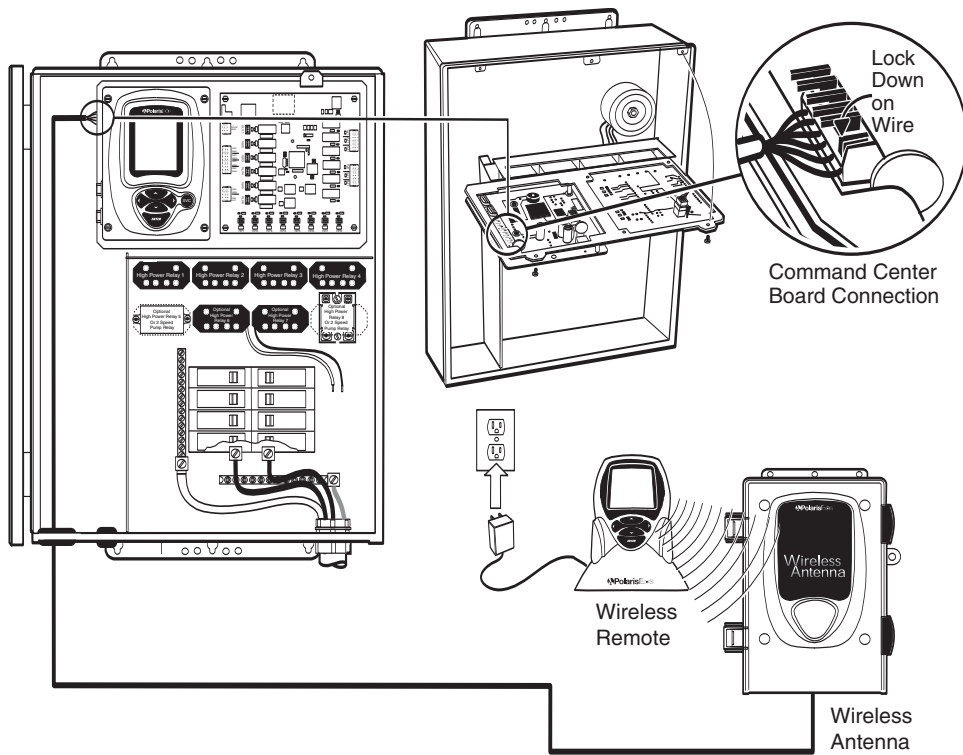

Opened Antenna Box

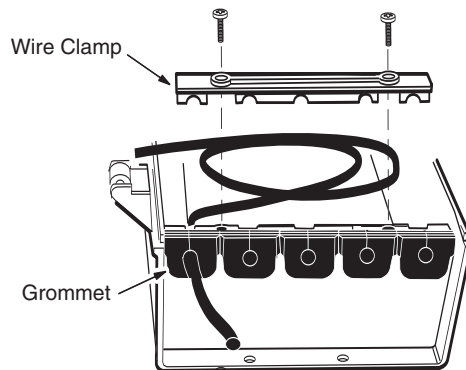
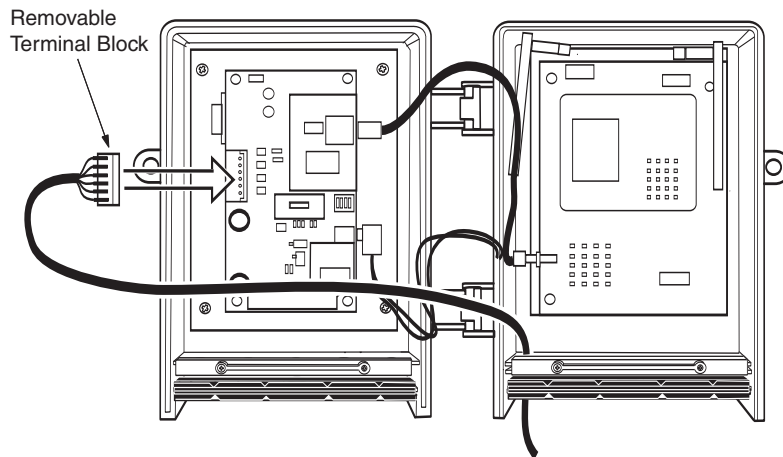

Optional Wireless Remote and Antenna



Wireless Antenna

Mount the antenna in a high location, in line-of-sight with the wireless remote and in the center of the coverage area. Avoid areas where the radio signal must pass through fencing, stucco walls, reinforced block walls, etc.

1. Open the antenna door and connect cable wires to the removable terminal block using this color-coded sequence:

Pin #	Wire Color
1	Green
2	Yellow
3	Orange
4	Red
5	Blue + Brown
6	Black + Purple

2. Remove the wire clamp and feed the wire into the left-most position, leaving about 12" of extra cable in the box. Push the wire into the rubber grommet seal. Reinstall the clamp and close the box.
3. Route the antenna cable to the Eos Command Center and in through the low voltage compartment.
4. Unscrew and swing down the hinged board plate to access the circuit boards.
5. Connect the antenna wire to the removable terminal on the command center board using the same pin/color sequence set above. To connect multiple remotes with the antenna, install a RBC Hub Card (part #E36).

For installations with multiple antennas, the wires can terminate at the Command Center or be wired to the terminal block of another antenna or wired remote (max. 2000 ft.).

After all connections are complete, power-up the Eos Command Center and Eos Wireless Remote to verify that communication has been established.

Wireless Remote

Position the remote and charging base in a location away from prolonged direct sunlight.

The wireless remote uses the Polaris rechargeable Lithium ion battery (part #E33). The battery **must be charged for at least five (5) hours before use**. Charging is indicated by an animated scrolling of the battery symbol on the display.

With a full charge, the remote can operate for up to two days, depending on usage. It is normal for the battery to discharge when not in use. To ensure a full charge, always store remote on the charging base when not in use.

Changing the Battery

1. Remove the screws and separate the back from the remote.
2. Remove the old battery and gasket.
3. Replace the battery.
4. Position the new gasket, verifying that it fits evenly around the perimeter of the back panel of the remote.
5. Secure the back of the remote to the front.

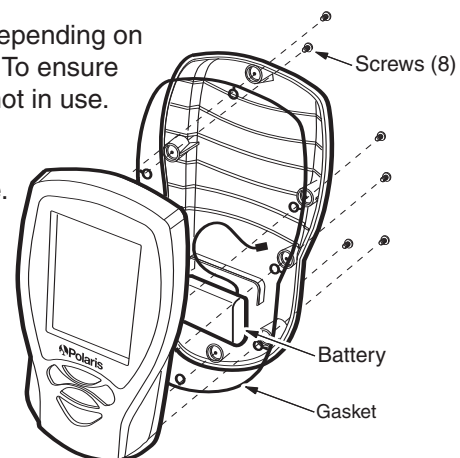

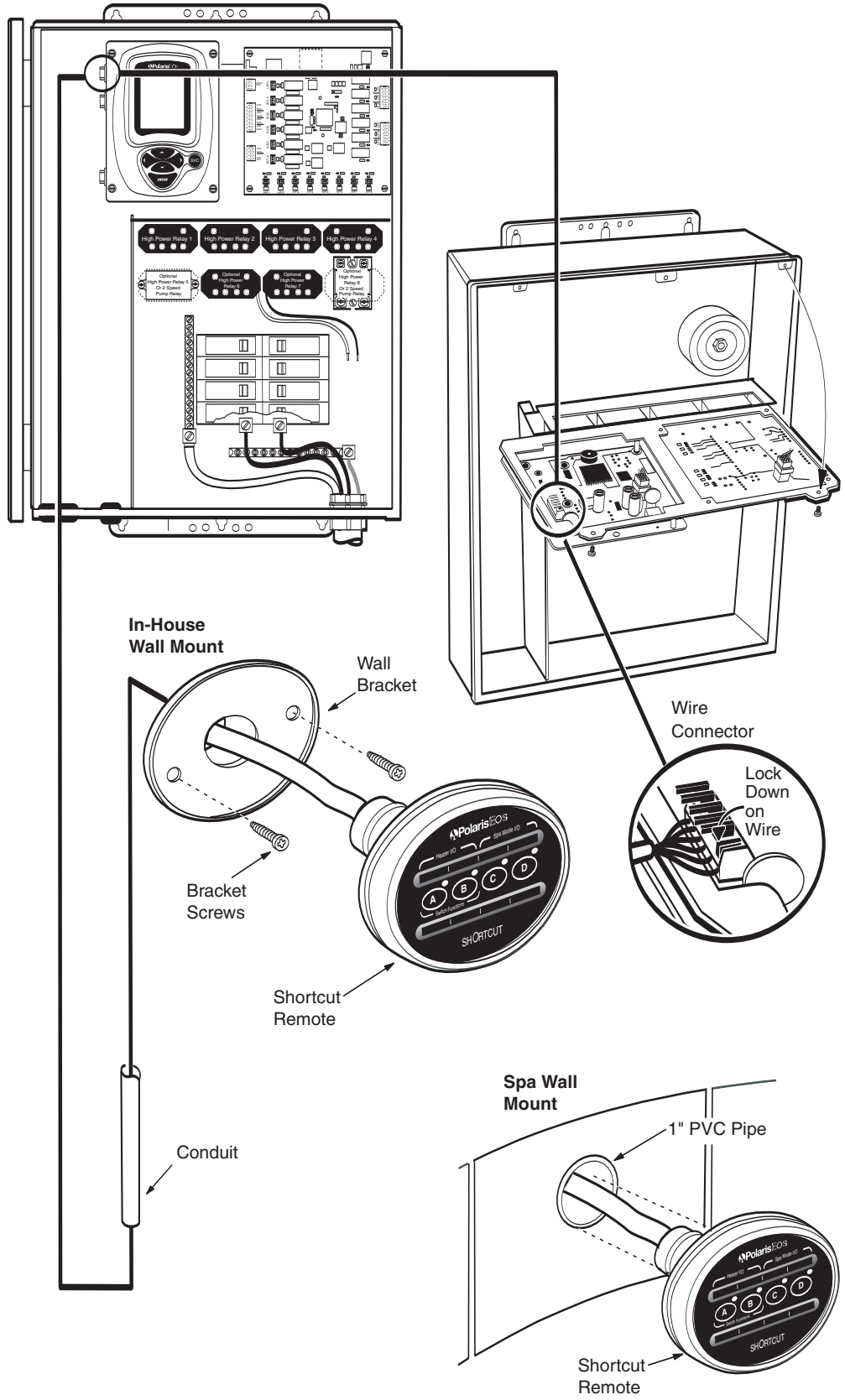



Optional Shortcut Remote

The Shortcut remote offers up to eight function assignments and two additional factory-set controls to provide full 10-function capability.

It can be installed as an in-house panel or as a spa-side remote.

1. **When mounting as an in-house panel**, use a level and template to measure, then drill holes to secure the mounting bracket. Pull the remote cable through the mounting bracket and secure the bracket to the wall. Push remote securely onto bracket.

When mounting as a spa-side remote, plumb a 1" dia. Sch. 40 PVC pipe to the spa wall, at least 4" below the deck level. Push remote securely into pipe.

2. Pull the 6-wire remote cable to the Eos Command Center and route it through low the voltage compartment. Cut off excess cable, do not coil it inside the command center.
3. Unscrew and swing down the hinged board plate to access the circuit boards.
4. Attach the wires to the removable terminal block on the command center circuit board using the following pin/wire color sequence.

Pin #	Wire Color
1	Green
2	Yellow
3	Orange
4	Red
5	Blue
6	Black

To connect multiple remotes, install a RBC Hub Card (part #E36).

5. When the connection is complete and **all equipment has been setup in the system**, assign the remote button functions using the Shortcut Setup option on the Device Setup screen. (See System Setup)



RBC Hub Card

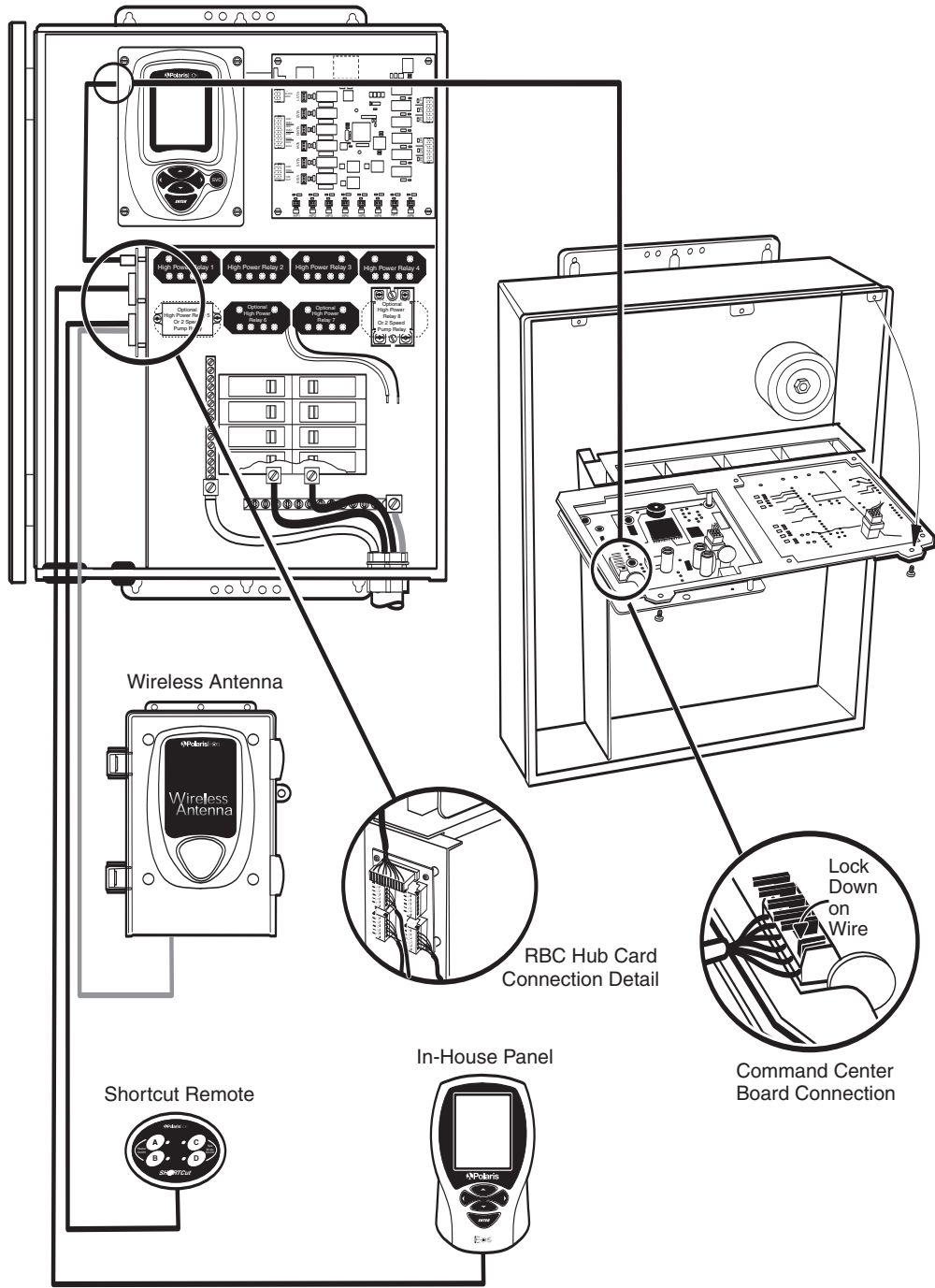

Optional RBC Hub Card

The hub card expansion connector allows four RBC devices (In-House Panel, Wireless Antenna, Shortcut) to be connected to the Eos Command Center simultaneously.

1. Attach the hub card to the wall of low voltage compartment in the Eos Command Center using the pre-drilled holes to hold the card standoffs.
2. Attach the hub card wires to the removable terminal block on the command center circuit board using the following pin/wire color sequence.

Pin #	Wire Color
1	Green
2	Yellow
3	Orange
4	Red
5	Blue
6	Black

3. Wire the RBC devices to the removable terminal blocks on the hub card following the pin/wire color sequence for the specific device.



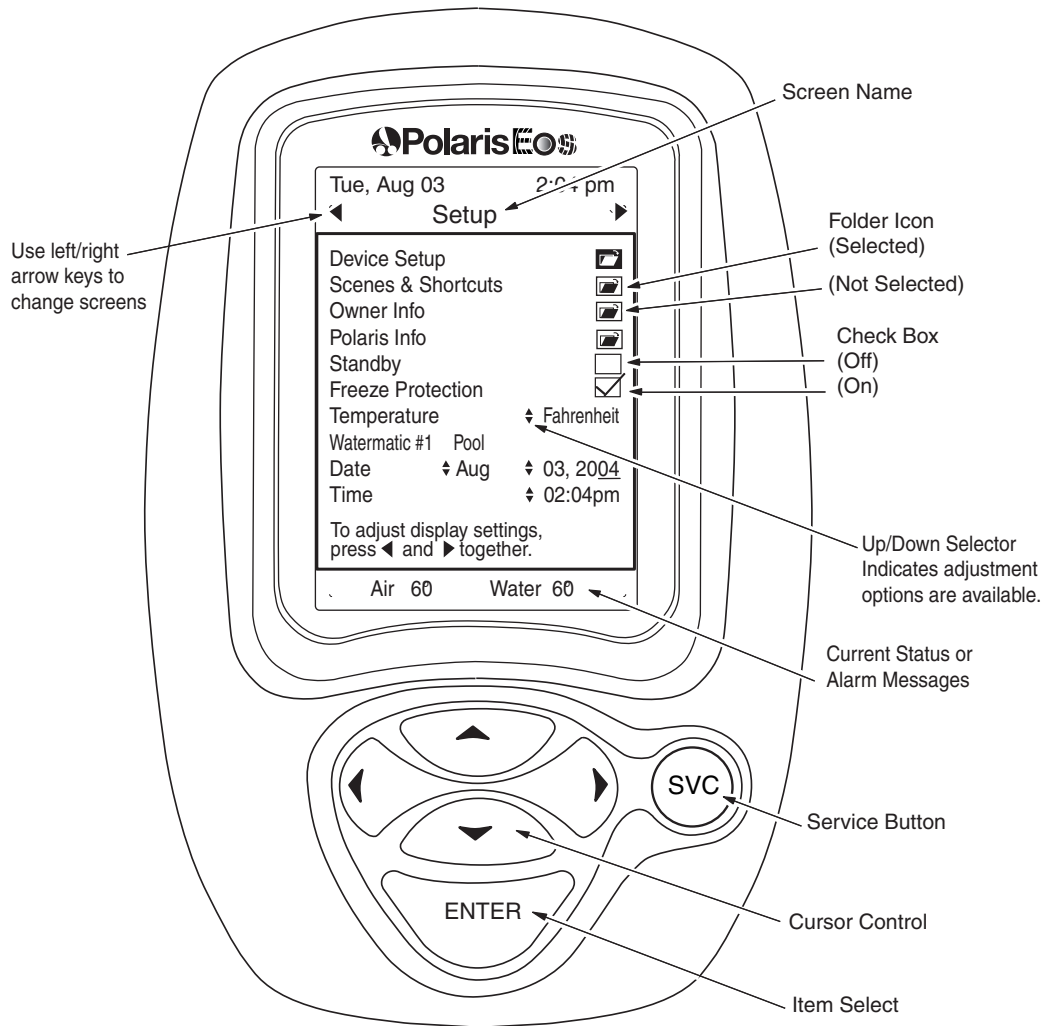

Operation



Starting the Eos Command Center

To activate the Eos Command Center, turn on power at the main electrical service panel. The circuitry will perform a self-diagnostics test.

To disable the command center (put it in “Standby Mode”) press and hold the <Enter> key for five seconds. Press any key to reactivate.

The Setup screen will appear on the command center display screen. (If a Watermatic controller or salt chlorinator is installed, the associated control screens may be displayed. Use the left or right arrow keys to move to the Setup screen.)

To adjust **display settings** such as brightness, contrast, backlight duration, etc., press the left and right arrows simultaneously to open the Command Center Setup screen. The current software version is also displayed on this screen.

Display settings can be adjusted independently for each display device: the command center or either of the remotes.

System Setup

All equipment controlled by the Eos Command Center must be defined and configured in the system at startup. Date, time, owner info and other general information must also be entered.

Screen Displays

Measurements and settings are shown on the command center display screen. Adjustments to settings are made with the keypad. Use the cursor control (arrow) keys to move through the screens and menu options. Use the enter key to select an item.

 **Folders** indicate that additional screens, menu or setup options, are available for an item.

 **Check boxes** turn functions on or off.

◆ The **up/down selector** indicates an adjustment option is available. Use the up/down arrow keys to selector or enter the setting.

To set or adjust an item:

1. Use keypad arrow keys to move the cursor over the item.
2. Press <Enter> to select the item. The item will flash.
3. Use the up/down keys to choose or enter the setting.
4. Press <Enter> to activate the setting.



Setup Screen

If the Setup screen is not displayed at startup, use the keypad to move to the screen to review the Setup options.

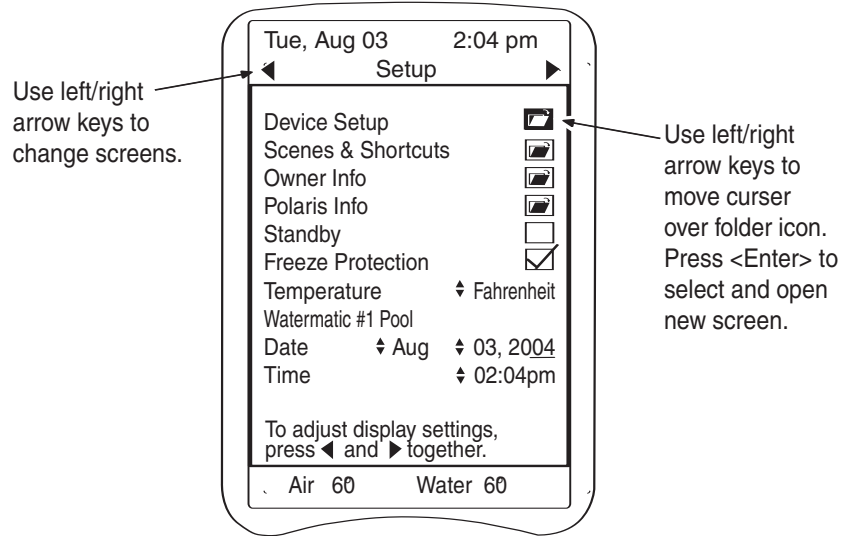

Device Setup

Defines and configures the equipment, pumps, lights, heaters, valves, temperature sensors, etc. that the command center will control. **Complete Device Setup prior to any other setup as subsequent setup specifications are often dependent on the configuration of the equipment.**

Scenes & Shortcuts

Establishes user-defined shortcuts that allow several devices to be started and stopped with a single command. For example, "Party" may be setup to turn on all outdoor lights and switch to spa mode with a predetermined temperature. All system device connections and setups must be complete before scenes or shortcuts can be established.

Owner Info

Select folder icon to open Owner Setup screen. Use the up/down arrow keys to move through the alpha-numeric options and the left/right arrow keys to move within the field. Press <Enter> when the entry is complete.

Polaris Info

Select to enter Polaris information such as serial number and service contact phone number.

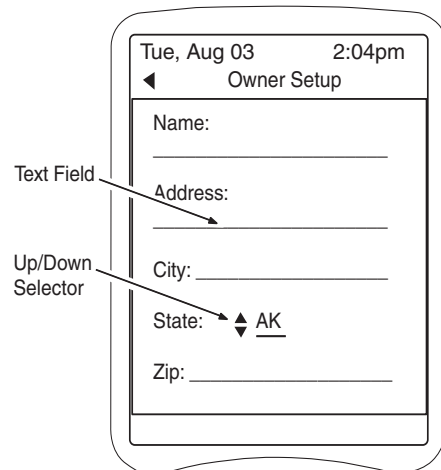



Standby

Checking the Standby box, puts the unit in Standby Mode which disables all automatic control functions. This is useful when troubleshooting or maintaining pool equipment.

Freeze Protection

To protect equipment, Freeze Protection should always be checked. It can be disabled while troubleshooting or maintaining pool equipment. **Freeze protection must also be specified for each individual device (i.e., pumps, valves, etc.).**

Temperature

Defines how temperatures are displayed: Fahrenheit or Celsius.

Date

Sets the current date so equipment start and stop schedules can be established correctly.

Time

Sets the current time so equipment start and stop schedules can be established correctly.

Watermatic #1 (text field)

This field will **only be displayed if a Polaris Watermatic C2100 ORP/pH Controller is installed** on the system. It names the Watermatic controller or controller location.

Use the up or down arrow keys to move through the alpha-numeric options and the left/right arrow keys to move within the field. Press <Enter> when the entry is complete.

Watermatic #2 (text field)

If a second Polaris Watermatic C2100 ORP/pH Controller is installed, this field identifies the controller or location and a separate Watermatic #2 control screen is available.

Watermatic Controller Control Screen

If a controller is installed, a separate control screen is provided to monitor readings and setup the controller parameters. Refer to the C2000/C2100 Owner's Manual

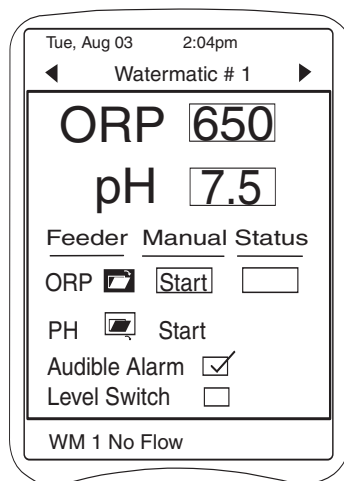



Salt Chlorinator Control Screen

If a Polaris AutoClearPLUS or other salt chlorinator is installed, a control screen is provided to monitor the salinity, set modes and adjust chlorine output.

Salinity

Displays the current salt concentration of the pool in parts per million (PPM). Consult the chlorinator owner's manual for recommended salinity ranges.

Mode ⚡

Normal – Chlorine production at normal rate.

Super – Produces the maximum amount of chlorine for 24-hours, then reverts back to normal mode. If selected, the pool pump must be activated for a 24-hour run cycle as well.

Service – Disables control while chlorinator is being serviced.

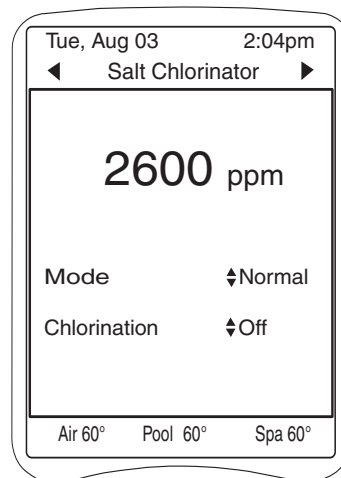

Chlorination ⚡

Adjusts the chlorine output from 0 to 100% in increments of 10.

Command Center Setup Screen

Display settings such as brightness, contrast, backlight duration, etc. are adjusted separately for each display device using the associated display setup screens. Some device-specific (i.e. remote only, etc.) functions are also available on these screens.

Press the left and right arrows simultaneously to access:

Software Version

Provides information on the current software versions for the command center and the various devices it controls.

Contrast and Backlight ⚡

Adjusts display features to user preferences.

Backlight Timeout ⚡

Sets a time limit for inactivity after which the backlight on the display turns off. Hit any key to reactivate the display.

Audible Alarm

Activates and deactivates the alarm, within this device, which sounds when an alert condition is present. Alert messages are displayed on the Main screen.

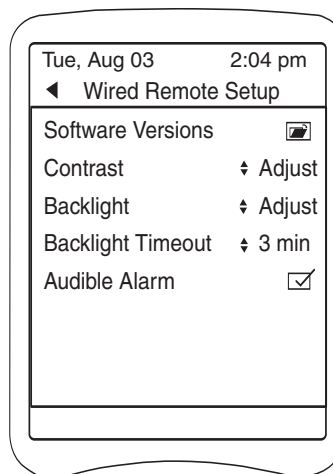



In-House Panel (Wired Remote) Setup Screen

Similar to the Command Center Setup Screen, the In-House Panel setup screen offers lighting and contrast adjustment as well as the alarm option.

Software Version

Specifies the active software version.

Access Code

An additional security feature available on the remote display devices, the Access Code limits system change capabilities to authorized users.

1. When the check box is activated, a new screen opens and requests a code.
2. Press any four keys on the keypad, in any order.
3. All function selections are locked, requiring input of the access code to make changes.

Remote Channel \updownarrow

If two In-House Panels are installed on a system, the second must be adjusted to a different channel to allow simultaneous use.

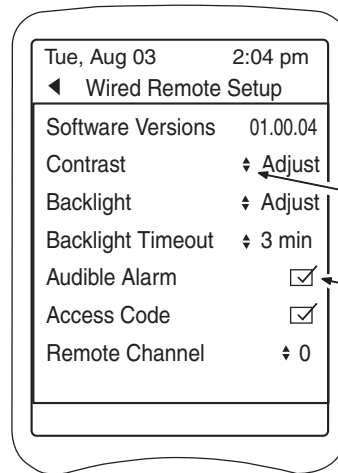

Up/down keys adjust setting.

Press <Enter> to select and activate.

Wireless Remote Setup Screen

Software Version

Accesses current system software information.

Network Settings

Preset at the factory, no adjustments are necessary. Includes the unique remote channel setting required for each wireless remote.

Shutdown

Turns off the remote. Useful to conserve battery life. Press any key to reactivate remote.

Audible Alarm

When activated, the alarm in this device signals when an alert condition exists. Alert messages are displayed on the Main screen.

Spa Temp Notify

Sounds an alarm when the water temperature in the spa reaches its designated set point.

Access Code

Allows establishment of the four key-stroke security code.

Contrast and Backlight \updownarrow

Adjusts display features to user preferences.

Sleep Timeout \updownarrow

To conserve battery life, the remote can be switched to sleep mode after a specified length of time without activity.

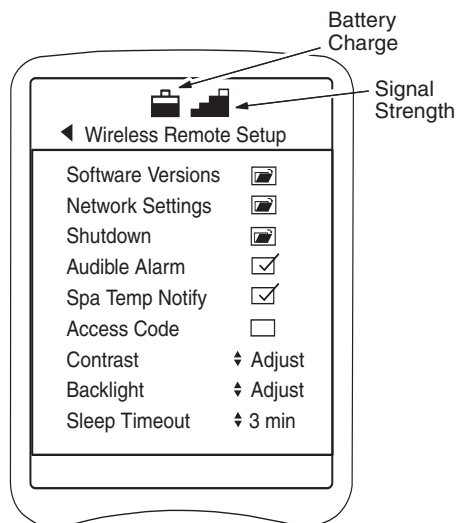

Battery Charge

Signal Strength



Device Setup Screen

Device Setup defines the system configuration and lists the devices to be controlled by the command center. Equipment is broken into categories and specified according to the system configuration.

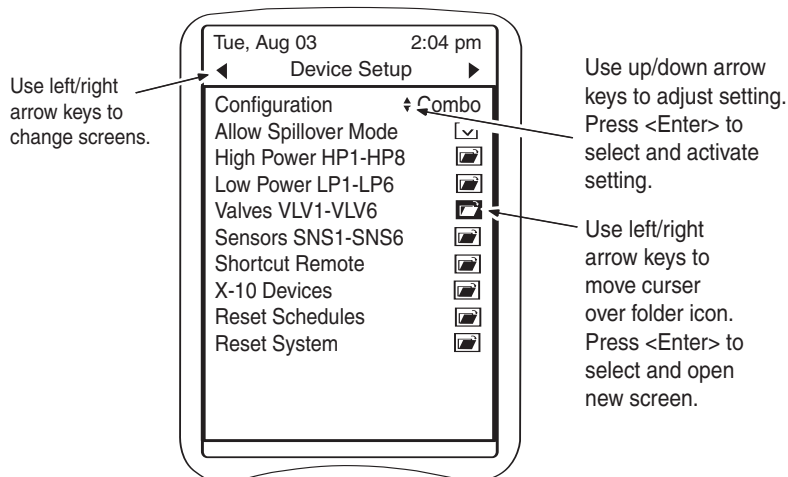

Configuration

Specifies the configuration of the system. Must be selected prior to the setup of individual devices as it determines subsequent equipment options. For example, suction and return valves are not valve options if the system is setup as Pool Only.

Configuration options:

Combo – for a pool/spa combination installations.

Pool Only – for pool only installations.

Spa Only – for spa only installations.

Separate – for pool/spa installations that are plumbed separately but controlled by a single Eos Command Center.

None – Use when the Eos Command Center controls only auxiliary equipment such as landscape lighting, ceiling fans, etc.

After a configuration selection is made, a confirmation screen will appear. Move cursor to Yes and press <Enter> to activate the selection.

Allow Spillover Mode

If a pool/spa combo configuration is specified, this option becomes available. Check to allow the spa spillover mode.



High Power HP1-HP8

Defines the high power (90-250 VAC) devices that are controlled by the system.

Use the lists, accessed with the up/down keys, to assign each device to the high power relay it is wired to. For example, if the circulation (filter) pump is wired to relay #3, setup HP3 as "PS Circ Pump." ("PS" stands for Pool/Spa, used in combo system)

If the circulation pump is two-speed, identify the standard relay as high-speed and the 2-speed relay as low-speed.

Some devices, such as a dimmer, require input of a custom name.

The check boxes to the right of each device, when checked, activate the device to allow immediate verification of operation.

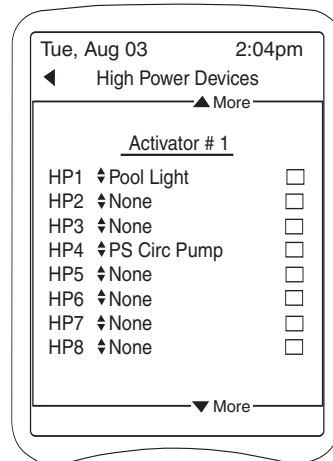

Low Power LP1-LP6

Defines the low power devices. Assign each device to the appropriate terminal.

Valves VLV1-VLV6

Defines the valve actuators used in the system. In a Pool/Spa Combo installation, identify the suction valve and return valve separately. Assign each valve to the appropriate valve position.

Sensors SNS1-SNS6

Defines the sensors available on the system.

There are five possible temperature sensors and one filter pressure sensor. One air and one water sensor (PS Sensor) are included.

The pressure sensor can monitor filter pressure and automate backwashing of a sand filter.

Assign each temperature sensor to the appropriate terminal position and the pressure sensor to PRES.

Calibration allows the user to calibrate the sensors, +/- 5°.

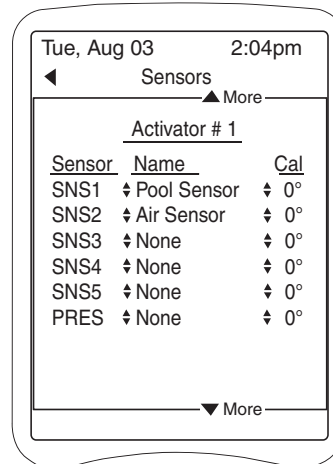

If an Eos Expansion Panel is installed, use the up/down arrow keys to move to the next screen to assign HP devices, LP devices, etc. for Activator # 2. Subsequent screens enable device designations for Activator #3 and Activator #4.



ShortCut Remote (optional)

Since the Shortcut remote controls equipment (pump, light, heater, etc.), all **devices must be setup first** to make the button (Key A, B...) functions available. Use the lists, accessed with the up/down keys, to assign each button function.

Scenes and Shortcuts can be assigned to a button function allowing multiple device activation.

If lights (including dimmers) are setup, the remote controls only the on/off function of the device.

Temperature controls are the default on buttons A and B, if a heater has been setup.

After assigning button functions, mark buttons with the device identifier labels provided.

The check box enables the Shortcut (#1 or #2).

Buttons light when their respective device is active.

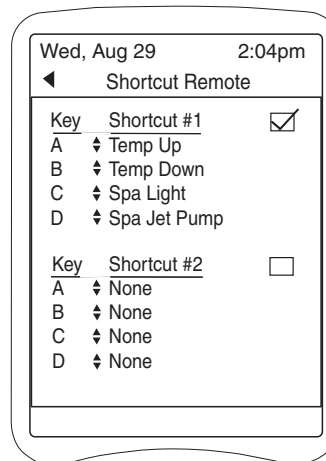

Switch from Shortcut #1 and Shortcut #2

Access device options of Shortcut #2 by pressing buttons A and C simultaneously. The two buttons will flash and then the active shortcut button (i.e. A = Shortcut #1) will illuminate.

Activate Spa Mode

Press buttons C and D simultaneously to activate spa mode. All buttons will flash.

Activate Heater

Press buttons A and B simultaneously to activate the heater. The two buttons will flash.

PLC (X-10) Devices (Optional)

Names the PLC device and assigns the house code (A-P) and device codes (1-16) established on the PLC receiver. Enter device name in the text field using the up/down keys. Press <Enter> when input is complete.

Use the down arrow to move through the screens to assign all devices.

If a dimming PLC receiver is installed, check the dimmer check box to enable dimming control for the device.

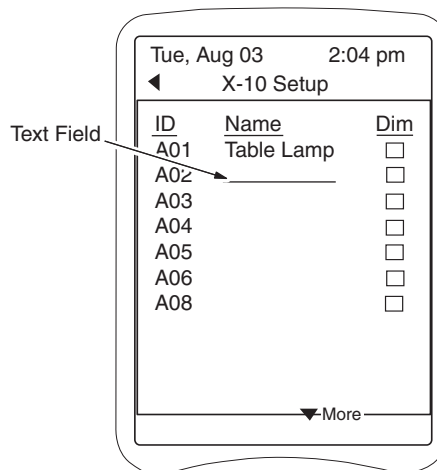

Reset Schedules

Clears all device schedules. A confirmation screen will verify this selection before initiating the change. Select Yes and press <Enter> to activate reset. **There is no retrieval of deleted schedules.**

Reset System

Clears all system settings: HP Setup, LP Setup, etc. A confirmation screen will verify this selection before initiating the change. Select Yes and press <Enter> to activate reset. **There is no retrieval of the deleted configurations.**



Main Screen

Once the setup procedures are complete and the system devices are defined, the Main screen is displayed with the installation-specific device functions. This screen shows designated set points, lists the devices installed and displays current operational status readings.

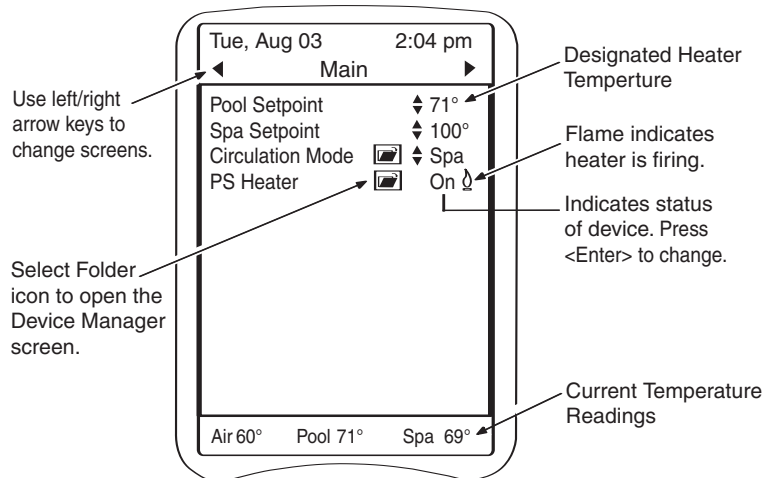

Main Screen Tips and Tricks

Use keypad strokes to reposition listings or reactivate displays.

Insert or delete lines between menu items.

1. Move cursor to Status field.
2. Press and hold <Enter>.
3. Press the up and down arrow keys simultaneously.

Move a device item up or down on the menu.

1. Move cursor to the Status field of the particular device.
2. Press and hold <Enter>.
3. Push up or down arrow key to move device name.

Reset the wireless display when it is locked-up/frozen.

1. Press and hold <Enter>.
2. Press left and right arrow keys simultaneously.



Device Manager Screen

Sets the mode or status for a device, controls manual operation, defines schedules and specifies device specific functions when applicable.

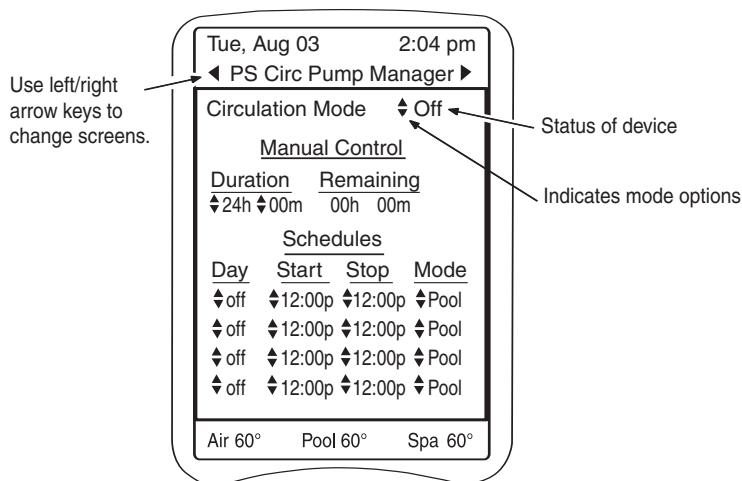

Status

Indicates on/off status for most devices. For the pool/spa pump it also indicates the current circulation mode (pool, spa, or spillover). Select and press

Manual Control ⚡

Specifies how long a device will be active when turned on or inactive when turned off manually. When the specified manual control duration is complete, the device control returns to established schedules.

Manually activated devices are subject to device manager rules; therefore, even though a device may be “on”, it may not activate unless all rules are met. See **Safety Delays and Lockouts** for further information.

Schedules ⚡

Defines activation schedules for the device. Up to four schedules can be set. Schedules are based on date and time.

Day: Specifies day(s) of scheduled operation
(Sun, Mon, Tue, Wed, Thu, Fri, Sat individually or All)
(M-F = Monday thru Friday)
(S-S = Saturday and Sunday)
(MWF = Monday, Wednesday and Friday)

Start: Specifies start time

Stop: Specifies stop time

Mode: For pump: specifies circulation mode (pool, spa, spillover)

It is important to take into consideration the operation of each piece of equipment. Some equipment may need other equipment to operate correctly. When scheduling, review all programmed equipment to see if there are potential conflicts that could diminish efficiency or eliminate the operation altogether.

A pool, spa or spillover schedule will automatically turn the filtration pump on, a second pump schedule is not necessary.



Some equipment, such as heaters, solar valves, etc. have device-specific options listed on Device Manager.

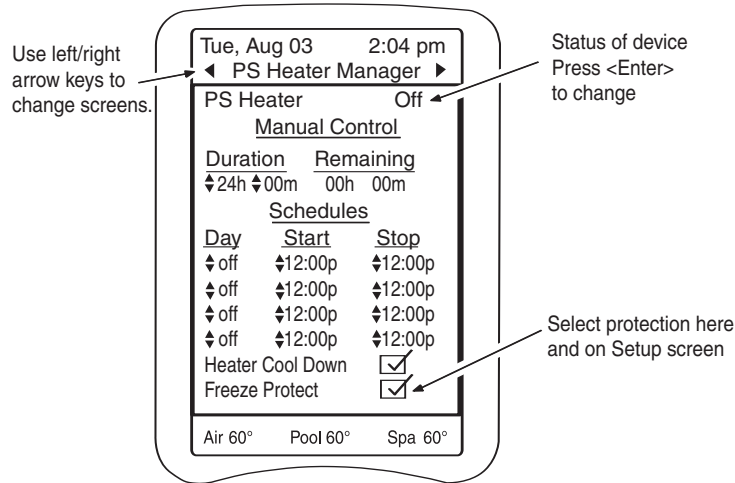

Heater Cool Down

Provides a three minute-delay in turning off the circulation pump to allow the heater to cool down.

Freeze Protection

Enables or disables freeze protection for the device. Once assigned, designated equipment will be activated when Eos detects freezing conditions. By default, the main filter pump is freeze protected at the factory. The freeze protection temperature is preset to be 38° F and cannot be changed.

System Operation

When all equipment setup is complete, manually check the operation of each device using the check boxes on the individual **Device Setup** screens (select Device Setup folder on Setup screen, then the device folder for each type of equipment, i.e. high power, low power, valves, etc.) or by changing the device status on the **Main** screen.

Note: Manually activated devices are subject to device manager rules; therefore, even though a device may be “on”, it may not activate unless all rules are met. For example, although the heater is turned “on”, it will only fire (indicated by the flame) if the circulation pump is on and the temperature setpoint is above the current temperature reading.

During normal operation, the **Main** screen provides access to the most commonly needed information, temperature setpoints, status of devices and quick access to device schedules.

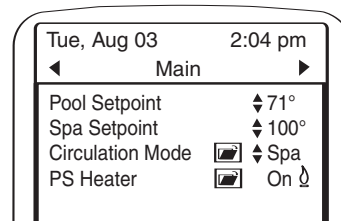
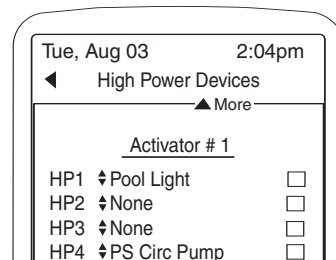



Scenes & Shortcuts

Use scenes and shortcuts to simplify system operation.

A Scene is a “snapshot” of the entire system operation that can be recalled to play at any time. A scene could be set to: dim the lights to 50%, heat the spa to 100 degrees and turn on the blower. Scenes can be scheduled to run at specific times; however, only one scene can be played at a time. If a Scene is “in play” and another is recalled (either manually or by schedule), the latter scene takes priority. As a complete system “snapshot,” a scene will activate devices as well as turn them off.

Shortcuts are also recallable “snapshots” of system operation; however, shortcuts only turn on devices, they do not turn off devices. Multiple shortcuts can be active simultaneously. **If a shortcut is active and a scene is recalled, the scene will override the shortcut.** However, if a Scene is playing, a Shortcut can be activated and will continue to run simultaneously.

The Scenes & Shortcuts screen is accessed from the folder icon on the Setup screen.

The system allows up to five of each type to be setup.

To establish a scene or shortcut:

1. Use the arrow keys to input a name in the text field on Scenes & Shortcuts screen.
2. Move the cursor to the folder icon and press <Enter> to access the Shortcut or Scene Manager screen.
3. Status should display “Off.”
4. Set the manual control definitions.
5. Set the schedules for the shortcut or scene.
6. Once the scene is defined, turn on all equipment that is part of the scene and turn off equipment that is not.
7. Move the cursor to Save and press <Enter> to capture and save the device configuration. Select the Save command any time the Scene or Shortcut needs to be changed.

When a scene or shortcut has been established, it will be displayed on the Main screen as if it were a device. A folder icon is provided to access the associated manager screen.

Eos Software Applications

E3 Simulator Application

Available for use as a training tool, the application runs on any PC and simulates the Eos control screens and functionality. Contact Polaris for a free copy.

Code Download Application

Enables software updates in the field. Contact Polaris for a free copy.

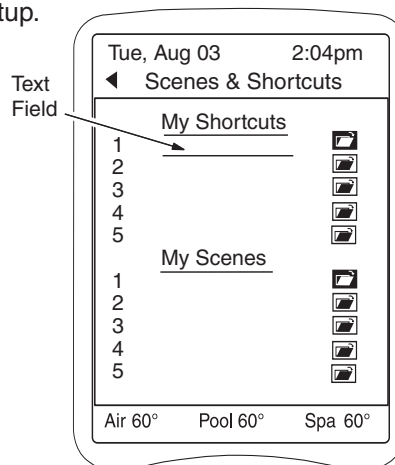



Datalogger Application

The Eos system records equipment status, alerts and various events from the Watermatic system on a daily basis. Data is collected whenever there is an event change. The system can hold several weeks to a month worth of data depending on system activity.

Using any PC computer and a standard serial cable, data can be retrieved and reviewed by means of the Polaris Eos Datalogger Application (part #E83).

1. Connect serial cable to the serial port on the Eos Command Center board.

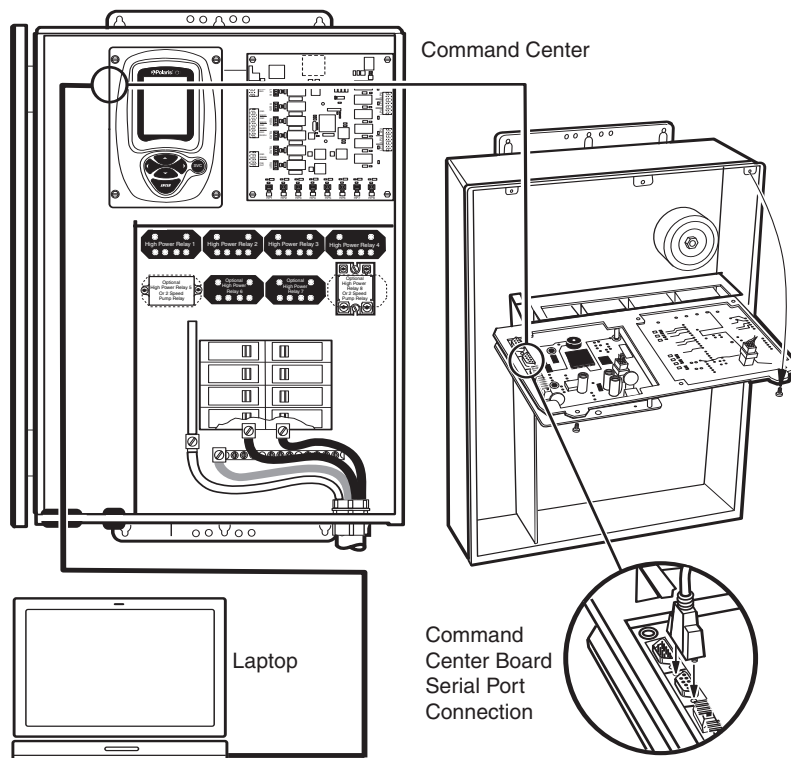

PC Access Application

With the use of the Eos PC Access Application software (part # E82), the Eos system can be controlled remotely from any home laptop or PC.

Control access can be obtained through the same serial port connection used by the Datalogger or wireless communication can be established by means of the PC wireless card and an access port in the Eos Wireless Antenna (part #E32).

Set the PC network settings to the Eos system settings:

SSID = Zeros with nine digit antenna serial number. (i.e. 0000000xxxxxxxx)

Network Authorization = Open

Data Encryption = 128 Bit WEP

Network Key = Zeros with nine digit antenna serial number. (i.e. 0000000xxxxxxxx)

Channel = Auto

Band = 802.11a

Data Rate = 54 Mbps (Do not use Turbo Mode.)

IP Address = Assigned by DHCP



Service Mode

To enter service mode, press and hold the SVC key for two seconds. The Service screen will open.

Timeout

Disables established activation schedules, scenes or shortcuts so equipment can be turned on and off for service. Set for one (1) minute to four (4) hours as needed.

When timeout is complete or service mode is exited, all established schedules will resume.

System valves are listed first. Only one valve can be activated, via the check box, at a time. If a second is selected, it will override the first selection.

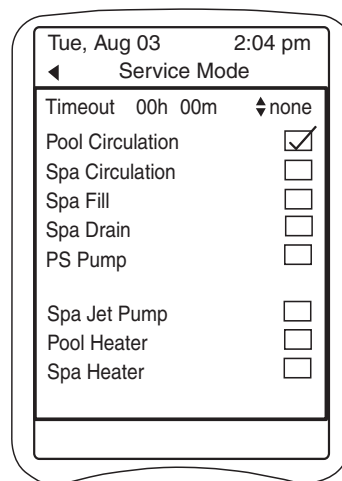

Alerts and Alarms

The following alert conditions will sound the audible alarm in addition to displaying the alert.

Alert

Pool High Temperature
Pool Low Temperature
Spa High Temperature
Spa Low Temperature
Wireless Remote Battery Low
WM#1 High PH Alert
WM#1 Low PH Alert
WM#1 High ORP Alert
WM#1 Low ORP Alert
WM#1 PH Overfeed
WM#1 ORP Overfeed
WM#1 Feeder Empty

Alert

WM#2 High PH Alert
WM#2 Low PH Alert
WM#2 High ORP Alert
WM#2 Low ORP Alert
WM#2 PH Overfeed
WM#2 ORP Overfeed
WM#2 Feeder Empty
Salt Chlorinator PCB Error
Salt Chlorinator Very Low Salt
Salt Chlorinator High Current
Salt Chlorinator Low Voltage

The following Alerts are flashing messages only.

Alert

Freeze Alert
WM#1 No Flow
WM#1 2 Minute Flow Delay
WM#1 Clean PH Sensor
WM#1 Cal PH Sensor
WM#1 Clean ORP Sensor
WM#2 No Flow
WM#2 2 Minute Flow Delay
WM#2 Clean PH Sensor
WM#2 Cal PH Sensor
WM#2 Clean ORP Sensor
Solar Purge Delay
Solar Panel Temp Too Low
Spa Has Reached Set Temp

Alert

Cleaner Requires Pool Mode
Standby Mode
GPC-ACT Comm Failure (Cable/Activator)
GPC-EXP Comm Failure (Expansion Bd)
GPC-IRR Comm Failure (Irrigation)
GPC-WM1 Comm Failure (Watermatic)
GPC-WM2 Comm Failure
SCB Comm Failure
X10 Comm Failure
Salt Chlorinator Low Salt
Salt Chlorinator Clean Cell
Valves Turning
Heater Cooling Down

Safety Delays and Lockouts

1. Heater

When activated (turned on manually or via the schedule), the heater will only fire (indicated by flame on display) if the circulation pump is on and the temperature setpoint is above the current temperature reading.

There is a one minute operational delay at initial startup of the heater. Once the heater is active and the desired temperature is reached, the heater will turn off and remain off until the temperature falls two degrees below the set point. This prevents the heater from short cycling (i.e. turning on and off in rapid succession).

After the heater shuts down, it enters a 3-minute cool down period. **Heater Cooling Down** will be displayed on the screen. If the filter pump is shut down during the cool down, the pump will remain on until the delay is finished and an hourglass will be displayed next to the pump on the screen.

2. Cleaner Booster Pump

The pool cleaner will only activate when the system is in the pool mode (i.e. water circulating to the pool) as it requires water circulation to function correctly. **Cleaner Requires Pool Mode** is displayed if cleaner schedule requires circulation mode adjustment.

There is a 30-second prime delay to ensure the water is flowing to the booster pump. The display will read **Prime Delay** during this delay.

If the filter pump is turned off while the cleaner booster pump is running, the controller will automatically shut down the booster pump. The system recognizes that the booster pump cannot run without the circulation pump.

If the booster pump cleaner is active and spa or spa spillover mode is entered the booster pump will shut down and be locked-out. When the spa or spa spillover mode is cancelled, the

booster pump schedule will resume.

3. Spa Drain

The spa drain can only be activated on the Service screen.

4. Valves

Valves Turning is displayed whenever a valve (pool to spa, spa to spillover, solar, etc.) is signaled to rotate. There is a 15 second delay during which the filter pump is shut off. The pump is reactivated when the valves have stopped turning.

5. When the equipment is manually activated:

Existing schedules will be overridden. Remember to shut down the equipment, otherwise, the equipment will continue to run until the next scheduled shut down or time-out specified in the device setup.

If spa mode is not turned off, only the water in the spa will be filtered and the pool cleaner will be disabled.

Turning off the filter pump will not reset the valves to pool mode. The valves will automatically return to POOL mode after 6 hours.

6. Solar Heating Systems

When solar heating is initiated and there is a booster pump cleaner on the system, the booster pump will shut down and be locked-out for a two minute **Solar Purge Delay** to allow water to be purged from the solar collectors. When the delay is complete, the booster pump is reactivated.

7. Communication Failures

Communication failure messages (**CPC-ACT Comm Failure, X10 Comm Failure, etc.**) will be displayed when there is a communications failure between the command center and the system components. Check connections or reposition the remote or antenna and try again.



Eos Automated Control System Limited Warranty

This limited warranty is extended to the original consumer purchaser of this Polaris Eos Control System (the "System") manufactured by Polaris Pool Systems, Inc. ("Polaris"), 2620 Commerce Way, Vista, California 92081-8438, U.S.A.

Polaris warrants the System, including all parts and components thereof, to be free of defects in material and workmanship. This limited warranty applies only to Systems which have been installed and maintained in strict accordance with the installation and operating instructions provided by Polaris, for its intended use with personal or single-family pools (commercial use is excluded), using installation hardware supplied and/or recommended in writing by Polaris, and to Systems which have been connected to the correct voltage supply. The instruction manual should be read in its entirety before the installation of the Polaris Eos Control System. Failure to follow the installation instructions may void this warranty. If you have any questions regarding this Polaris Eos Control System, please call or write us. Be sure to have the serial number of the unit available.

The Polaris Eos Control System is warranted for parts and labor for a period of one year from the date of manufacture of the unit as established by the serial number, or one year from the date of purchase of the Polaris Eos Control System with proof of purchase, whichever is later. This limited warranty does not apply if the failure is caused or contributed to by improper installation, handling, set up adjustments, usage, operation, storage, or maintenance. This limited warranty does not apply if the failure is caused or contributed to by a connection to improper voltage supply, power failure or reduction, signal interference problems, unsuitable application of the System, lack of reasonable and necessary maintenance, damage in transit or during installation, or damage from repairs/alterations/removal made or attempted by anyone other than Polaris or one of its Authorized Service Centers. This limited warranty does not cover cosmetic damage or damage due to acts of God, water, wind, rain, lightning, freezing, rodents or insects, accident, misuse, abuse, negligence, or modification of or to any part of the Polaris Eos Control System. This warranty does not cover consumables such as fuses or batteries. These are normal replacement items.

Polaris will repair or replace, at its option, the System or part or component thereof proven to be defective within the warranty period and under the conditions of the warranty. To make a claim under this warranty, the consumer must contact the Customer Service Department at 1-800-822-7933 (USA and Canada) or (760) 599-9600 with the serial number and proof of purchase. REPAIR OR REPLACEMENT AS PROVIDED UNDER THIS LIMITED WARRANTY IS THE EXCLUSIVE REMEDY OF THE CONSUMER. THIS LIMITED WARRANTY IS IN LIEU OF ALL OTHER WARRANTIES, EXPRESS OR IMPLIED, INCLUDING THE IMPLIED WARRANTIES OF MERCHANTABILITY AND FITNESS FOR A PARTICULAR PURPOSE AND ALL SUCH OTHER WARRANTIES ARE DISCLAIMED EXCEPT TO THE EXTENT ANY IMPLIED WARRANTY MAY BE IMPOSED BY STATE CONSUMER LAW. ANY SUCH IMPLIED WARRANTY IMPOSED BY STATE CONSUMER LAW IS LIMITED IN DURATION TO ONE (1) YEAR FROM THE DATE OF PURCHASE. IN NO EVENT SHALL POLARIS BE LIABLE FOR INCIDENTAL OR CONSEQUENTIAL DAMAGES OF ANY NATURE OR KIND OR FOR DAMAGES TO PERSONS OR PROPERTY, INCLUDING ANY DAMAGES RESULTING FROM THE FAILURE OF OR DEFECT IN ANY EQUIPMENT USED IN CONJUNCTION WITH THE POLARIS EOS CONTROL SYSTEM (E.G., PUMPS, FILTERS, BLOWERS, HEATERS, POOL CLEANERS, LIGHTING, WATER FEATURES, VALVES) OR IN USE WITH A SUBSTANDARD POOL CIRCULATION SYSTEM. THE ONLY REMEDY PROVIDED TO YOU UNDER AN APPLICABLE IMPLIED WARRANTY AND THE LIMITED WARRANTY SET FORTH ABOVE SHALL BE THE REMEDIES EXPRESSLY PROVIDED FOR UNDER THIS LIMITED WARRANTY.

This limited warranty gives you specific legal rights. You may also have other rights that may vary from state to state. Some states do not allow limitation on how long an implied warranty lasts, or the exclusion or limitation of incidental or consequential damages, so the above limitations may not apply to you.

This limited warranty is valid only in the United States of America and Canada, and it does not apply to Polaris Eos Control Systems sold or installed in any other country.



USA: 2620 Commerce Way, Vista, CA 92081-8438 • 760-599-9600 • 1-800-VAC-SWEEP (USA and Canada only)

Australia: Unit 4, 19-21 Gibbes Street, Chatswood, NSW 2067 • 02-9882-1111 • ACN 080 168 092

Europe: C/Osona s/n. (Pol. Ind. El Ramassar), 08520 Les Franqueses del Vallés, Barcelona, Spain • +34 93 840 25 85

www.polarispool.com